



EEVBlog



USER'S MANUAL 121GW MULTIMETER

Last Revised
24 September 2018

CONTENTS

Contact	5
Glossary of Terms.....	6
Change log.....	7
Firmware Version	8
General.....	9
FCC/IC Information.....	9
Information to the User	9
Introduction	10
Features	11
Specifications	13
General	13
Voltage Measurement.....	15
Current Measurement.....	16
Resistance & Capacitance Measurement.....	17
Diode Measurement.....	18
Frequency & Duty Cycle Measurement	19
VA Measurement	20
Temperature & Continuity	21
Bluetooth Specifications.....	22
Standards	23
Compliance Symbols	23
IEC Standards.....	23
ANSI Standards	23
Safety	23

Warning..... 24

Caution..... 27

Operation 28

Measuring 33

Voltage \tilde{V} ^{Temp} _{mV} 33

 dBm..... 35

Voltage ^{Low Z} \bullet 36

Temperature ^{Temp} _{mV} 37

Current \tilde{A} _{mA} \tilde{A} _{μ A} \tilde{VA} 38

 Burden Voltage 40

Resistance Ω ^{\rightarrow \leftarrow} _{\parallel} 42

Continuity Testing Ω ^{\rightarrow \leftarrow} _{\parallel} 43

Cable Break Testing Ω ^{\rightarrow \leftarrow} _{\parallel} 44

Capacitance Ω ^{\rightarrow \leftarrow} _{\parallel} 45

Frequency ^{ms %} **Hz** 46

Duty Cycle ^{ms %} **Hz** 47

Period ^{ms %} **Hz** 48

Diode Measurement Ω ^{\rightarrow \leftarrow} _{\parallel} 49

Power (VA) **mVA/VA** \tilde{A} _{μ A} \tilde{VA} 51

Data Logging..... 52

Backlight 53

Bluetooth..... 53

Measurement HOLD..... 54

Relative Measurement (REL)	55
MIN/MAX/AVG	56
Setup Menu	57
Temperature	58
Battery Voltage	58
Auto Power Off (APO)	58
Buzzer On/Off	59
LCD Contrast	59
Date.....	60
Multimeter ID	61
Logging Interval	61
Maintenance	62
Debugging.....	62
Cleaning and Storage.....	62
Fuse Replacement	62
Calibration.....	64
Calibration Mode.....	65
Saving Calibration Data	66
Loading Calibration Data	66
Zero Offset Calibration	67
Full Scale GAIN Calibration	68
Calibration Reference Table.....	69
Firmware Update	70
Warranty	71

CONTACT

If you have a warranty claim, you can contact us at the following email address:

sales@eevblog.com

This multimeter and accessories can be purchased from:

www.eevblog.com

Community Support for the meter is provided on the EEVblog Forum:

www.eevblog.com/forum

Issues should be reported in the Report an issue section of the multimeters official page:

www.eevblog.com/product/121gw/

Phone:

Ph: +61(2)8626 8743

GLOSSARY OF TERMS

IEC

(International Electrotechnical Commission)

An organisation that publishes various international standards relating to electrical, electronics and related technology.

ANSI

(American National Standards Institute).

Americas non-profit standards organisation that oversee the development and use of standards in various domains.

ETL

(ETL Testing Laboratories)

The compliance certification mark of Intertek Group in Europe.

OP

(Overload Protection)

The voltage that a function of the Multimeter than withstand.

Accuracy

The closeness of a measured value to a known standard.

Low Burden™

Provides low burden voltage when measuring current compared with typical multimeters, minimising impact on your in-circuit current measurements.

CHANGE LOG

The following represents the changes made to the manual:

Date	Changes
15/01/17	Added Serial Number section Added Hold requirement to save setup items Fixed various grammar errors Added Bluetooth symbol to frontpage
31/01/18	Changed incorrect fuse rating to 400 mA / 600 V HRC Fuse Added Low Z mode description
04/03/18	Added Multimeter ID to list on page 53.
11/04/18	Minor grammar and a spelling change. Added VA specifications Specification format changes
24/05/18	Added information about new firmware version 1.15 and 1.17.
09/07/18	Added information about new firmware version 1.21 and 1.22. Added more information about use of Low Z mode.
26/07/18	Modified formatting of VAC table. Described Relative mode. Improved burden voltage section steps. Fixed error in offset calibration table. Changed steps for all setup items to allow for units that have buzzer turned off. Some grammar errors resolved.
27/07/18	Updated IAP section, removed incorrect step.
24/08/18	Updated DC mode section description for clarity.
30/08/18	Updated sections on battery type. Added warning about lithium batteries.
11/09/18	Added information about 500VA range.

FIRMWARE VERSION

This manual is written for version 1.07 of the 121GW firmware. The following is a list of changes for each version:

Version	Changes
1.00	Added support for exporting and importing calibration data to/from SD card. Displays version number on boot.
1.01	Internal version.
1.02	Internal version.
1.03	Fixed possible import export calibration bug.
1.04	Resistance auto-ranging speed improved. Can now turn beeper off. Negative VA values now readable.
1.05	Further improved auto-ranging speed. Improved Low-Z measurement up to 20KHz.
1.06	Internal version.
1.07	Improved VA mode over-estimation error.
1.15	Improved display to show OFL in appropriate sections, fixed lookup table bug with various range.
1.17	Improved accuracy of voltage measurement in AC and DC VA modes.
1.21	Added support for °C and °F in the Bluetooth packet.
1.22	Added 2 more bits of data for the main data to accommodate values over 65535.
1.25	Auto-ranging loop in M Ohms range resolved. Burden Voltage glitch resolved.
1.26	Improved resistance range noise when logging.
1.51	208ms data logging interval -> 200ms. File date and time in file meta info corrected. DC+AC auto ranging loop issue resolved. Amp range sensitivity improved. AC mode frequency persistence issue resolved. VAC + LPF bargraph issue resolved.

GENERAL

FCC/IC INFORMATION

This device complies with Part 15 of the FCC Rules and CAN ICES-3(A). Operation is subject to the following two conditions: (1) this device may not cause harmful interference, and (2) this device must accept any interference received, including interference that may cause undesired operations.

INFORMATION TO THE USER

This equipment has been tested and found to comply with the limits for a Class B digital device, pursuant to part 15 of the FCC Rules. These limits are designed to provide reasonable protection against harmful interference in a residential installation.

This equipment generates, uses and can radiate radio frequency energy and, if not installed and used in accordance with the instructions, may cause harmful interference to radio communications. However, there is no guarantee that interference will not occur in an installation.

If this equipment does cause harmful interference to radio or television reception, which can be determined by turning the equipment off and on, the user is encouraged to try to correct the interference by one or more of the following measures:

- Reorient or relocate the receiving antenna.
- Increase the separation between the equipment and receiver.
- Connect the equipment into an outlet on a circuit different from that to which the receiver is connected.
- Consult the dealer or an experienced radio/TV technician for help.

WARNING

Any changes or modifications not expressly approved by the manufacturer could void the user's authority to operate the equipment.

INTRODUCTION

Congratulations on purchasing the EEVblog 121GW multimeter. It's one of the most feature packed small form factor meters on the market, designed to provide maximum functionality in as little bench space as possible. It provides many unique features not found on other multimeters, like low burden voltage measurement and display, simultaneous voltage and current (VA power) measurement, 15 V diode test voltage, Bluetooth built-in, and Micro SD card data logging.

You've made a wise choice buying this instead of some questionable quality cheapie, it should return the favour with many years of safe and accurate service.

That ETL logo you see stamped on the back of the meter ensures that the meter design has been *independently* tested to the latest IEC/UL/EN61010-1 3rd edition safety standard by Intertek.

With a genuine 600 V CAT III rating and proper 1000V HRC fuses and MOV+PTC protection you can feel confident and safe that you can use this meter on most high energy mains rated equipment.

And remember, don't turn it on, take it apart!

This meter is hackable, go for it.

Have fun.

Dave Jones

www.eevblog.com

FEATURES

Summary

- True RMS sensing up to crest factor 10 (AD8436 chipset)
- 600 V CAT III ETL Listed Rating
- 1000 V HRC fuses
- High voltage 15V diode test mode
- Dual 50,000 count display
- Relative Mode
- 1ms Peak Capture
- MIN, MAX or AVG on all functions
- Low Burden™ current measurement feature
- OPEN and CLOSED continuity testing (for wire breaks)
- Temperature, Capacitance, Frequency and Duty Cycle
- Unique burden voltage measurement & display in current mode
- Simultaneous voltage and current measurement and VA calculation
- Low Z input mode eliminates ghost voltages (not for under 12V)
- Automatic touch measurement data hold
- Audible and visual incorrect input jack warning
- Closed case calibration of individual ranges

Logging Capabilities

- Bluetooth LE (Low Energy) Communication
- Data logging onto a Micro SD card (CSV format)

Mechanical

- Compact size
- Backlit display

Software

- Android, iPhone, and Windows 10 support, [Mac]¹
- Updatable Firmware (via micro SD Card)

Batteries

- RTC Battery (CR1220)
- Main Battery (4 x AA)
- Long battery life of >500 hrs

¹ Under development

SPECIFICATIONS

The following specifications are given in SI units with their accuracy notated as \pm (% of reading digits) + (number of digits) unless otherwise indicated.

GENERAL

The following table represents general specifications (at $23^{\circ}\text{C} \pm 5^{\circ}\text{C}$):

Item	Specification
Display	4 $\frac{1}{2}$ digits 50,000 counts, dual display
Update Rate	5 times per second nominal
Operating Temperature	0°C to 50°C (32°F to 122°F)
Relative Humidity	< 75%
Altitude	Operating below 2000 m
Storage Temperature	-20°C to 50°C (-44°F to 122°F)
Temperature Coefficient	Temperature coefficient (Nominal): $T_c = 0.1 \times (\text{Specified accuracy}) / ^{\circ}\text{C}$
RMS Sensing	True RMS sensing (AD8436)
Ingress Protection	IP41
Pollution Degree	2
Safety	cETLus 3rd Edition, CAT III 600 V, CE Conformity, IP41, RoHS Compliant, IEC/EN61010-1: 2010 3rd Edition
Drop Protection	1 m
Transient Protection	6 kV 2Ω , Pulsed Source
E.M.C.	Commercial limits compliance with EN61326-1
Bluetooth	BLE112 Class 2
Chipset	Hycon HY3131 ST ARM STM32L152D
Overload Protection	
mA and μA	400 mA / 600 V DC/AC IR 10kA HRC FAST + DIODE
A and 500mA	11 A / 1000 V DC/AC IR 20 kA HRC FAST + DIODE

V & Auto V	600 V DC/AC RMS PTC & MOV Protection
mV, Ohm & others	600 V DC/AC RMS PTC & MOV Protection
Low Battery Voltage	Below approx. 4.2 V
Battery Type	4 x 1.5 V AA alkaline battery ² (ANSI/NEDA 15 A or IEC LR6)
Current Consumption	5 mA Typical
Battery Life	500 hours typical on Alkaline
Dimension	84 mm x 165 mm x 57 mm (3.31" x 6.50" x 2.24")
Weight	485 g (17.1 oz.) with batteries
Accessories	Rubber Boot, Temperature probe, Test leads, Carry Case
Optional Purchase Accessories	Magnetic hanger

² Use of lithium batteries may causes an issue due to their higher voltage.

VOLTAGE MEASUREMENT

The following section provides the specifications

	Range	Resolution	Accuracy	Test	
DC V	50 mV ³	1 μ V	$\pm 0.1\% + 10$	N/A	
	500 mV	10 μ V	$\pm 0.1\% + 10$	N/A	
	5 V	0.1	$\pm 0.05\% + 5$	N/A	
	50 V	1 mV	$\pm 0.05\% + 5$	N/A	
	500 V	10 mV	$\pm 0.05\% + 5$	N/A	
	600 V	0.1 V	$\pm 0.1\% + 10$	N/A	
AC V	50 mV ²	1 μ V	$\pm 1.2\% + 15$	45 to 400 Hz	
True RMS	500 mV	10 μ V	$\pm 0.8\% + 10$	45 to 400 Hz	
	5 V	0.1 mV	$\pm 0.3\% + 10$	45 to 400 Hz	
Crest-Factor <10	50 V	1 mV	$\pm 0.3\% + 10$	45 to 400 Hz	
	500 V	10 mV	$\pm 0.3\% + 10$	45 to 400 Hz	
	600 V	0.1 V	$\pm 0.5\% + 10$	45 to 400 Hz	
	50 mV	1 μ V	$\pm 2.0\% + 20$	0.4 to 5 kHz	
	500 mV	10 μ V	$\pm 1.5\% + 10$	0.4 to 5 kHz	
	5 V	0.1 mV	$\pm 1.5\% + 10$	0.4 to 5 kHz	
AC V+DC V	50 V	1 mV	$\pm 1.5\% + 10$	0.4 to 5 kHz	
	500 V	10 mV	$\pm 1.5\% + 10$	0.4 to 5 kHz	
	600 V	0.1 V	$\pm 1.5\% + 10$	0.4 to 5 kHz	
	5 V	0.1 mV	$\pm 1.0\% + 10$	45 to 1000 Hz	
	True RMS	50 V	1 mV	$\pm 1.0\% + 10$	45 to 1000 Hz
		500 V	10 mV	$\pm 1.0\% + 10$	45 to 1000 Hz
600 V		0.1 V	$\pm 1.0\% + 10$	45 to 1000 Hz	

This channel has overload protection for up to 600 V.

³ Using Relative Mode, zero with shorted test leads.

The AC Bandwidth extends beyond 5 kHz, but the meter is only specified and calibrated at 5 kHz. The AD8436 used specifies an additional 1% error up to 65 kHz. Higher frequency is possible with additional error above that again.

CURRENT MEASUREMENT

The following section refers to the current measurement ranges and their respective performances. The current measurement module is protected by a 400 mA / 600 V HRC Fuse and an 11 A / 1000 V HRC Fuse.

	Range	Resolu- tion	Accuracy	Tested @	Burden Volt- age ⁴
DC A	50 μA ⁵	1 nA	$\pm 1.5\%+15$	N/A	100 $\mu\text{V}/\mu\text{A}$
	500 μA	10 nA	$\pm 1.5\%+15$	N/A	100 $\mu\text{V}/\mu\text{A}$
	5 mA	0.1 μA	$\pm 0.25\%+5$	N/A	2 mV/mA
	50 mA	1 μA	$\pm 0.25\%+5$	N/A	2 mV/mA
	0.5 A	10 μA	0.75%+15	N/A	0.03 V/A ⁶
	5 A	100 μA	0.75%+15	N/A	0.03 V/A ⁶
	10 A	1000 μA	0.75%+15	N/A	0.03 V/A ⁶
AC A	50 μA	1 nA	$\pm 2.0\%+20$	45 to 1000 Hz	100 $\mu\text{V}/\mu\text{A}$
	500 μA	10 nA	$\pm 2.0\%+20$	45 to 1000 Hz	100 $\mu\text{V}/\mu\text{A}$
	5 mA	0.1 μA	$\pm 1.0\%+5$	45 to 1000 Hz	2 mV/mA
	50 mA	1 μA	$\pm 1.0\%+5$	45 to 1000 Hz	2 mV/mA
	0.5 A	10 μA	$\pm 1.5\%+15$	45 to 1000 Hz	0.03 V/A ⁶
	5 A	100 μA	$\pm 1.5\%+15$	45 to 1000 Hz	0.03 V/A ⁵
	10 A	1000 μA	$\pm 1.5\%+15$	45 to 1000 Hz	0.03 V/A ⁵

⁴ The measured burden voltage is displayed on the secondary display.

⁵ This mode will use the x10 amplified and may have additional offset error that should be REL'd out before measurement.

⁶ The burden voltage can change with the type of fuse fitted.

RESISTANCE & CAPACITANCE MEASUREMENT

The following section outlines the specifications for the impedance ranges

	Range	Resolution	Accuracy
R Ω	50 Ω ⁷	0.001 Ω	$\pm 0.5\%+20$
	500 Ω	0.01 Ω	$\pm 0.3\%+5$
	5 k Ω	0.1 Ω	$\pm 0.2\%+5$
	50 k Ω	1 Ω	$\pm 0.2\%+5$
	500 k Ω	10 Ω	$\pm 0.2\%+5$
	5 M Ω	0.1 k Ω	$\pm 0.3\%+5$
	50 M Ω	1 k Ω	$\pm 1.2\%+20$
C μF	10 nF	0.01 nF	$\pm 2.5\%+5$
	100 nF	0.1 nF	$\pm 2.5\%+5$
	1 μF	1 nF	$\pm 2.5\%+5$
	10 μF	10 nF	$\pm 2.5\%+5$
	100 μF	100 nF	$\pm 2.5\%+5$
	9999 μF	1 μF	$\pm 3.0\%+5$ ⁸

This channel has overload protection for up to 600 V.

⁷ Using Relative Mode, zero with shorted test leads.

⁸ Accuracies depend on capacitor type.

DIODE MEASUREMENT

	Range	Resolution	Test Current	Accuracy
Diode V	3 V	0.001 V	1.4 mA	Not specified
	15 V	0.001 V	7 mA	Not specified

This channel has overload protection for up to 600 V.

A nominal 2.2 K resistor (includes PTC) is in series with the voltage source and is what limits the test current.

FREQUENCY & DUTY CYCLE MEASUREMENT

	Range	Resolution	Accuracy
F Hz⁹	99.999 Hz	0.001 Hz	±0.1%+3
	999.99 Hz	0.01 Hz	±0.1%+3
	9.9999 KHz	0.1 Hz	±0.1%+3
	99.999 KHz	1 Hz	±0.1%+3
	999.99 KHz	10 Hz	±0.1%+3
Duty Cycle % ¹⁰	99 %	0.1 %	±0.2% + 5 + 0.2/kHz

This channel has overload protection for up to 600 V.

This range has an apparent 99,999 counts.

⁹ Sensitivity > 2.5 V RMS

¹⁰ 0.01 to 200 kHz, Pulse Width: >5 us, Sensitivity: > 2.5 V RMS

VA MEASUREMENT

Function	Range	Resolution	Accuracy
DC VA	250.00 uVA	0.01 uVA	±1.0% + 5 digits
	2500.0 uVA	0.1 uVA	±0.5% + 5 digits
	25000 uVA	1 uVA	±0.5% + 5 digits
	25.000 mVA	0.001 mVA	±0.5% + 5 digits
	250.00 mVA	0.01 mVA	±0.5% + 5 digits
	2500.0 mVA	0.1 mVA	±0.5% + 5 digits
	25000 mVA	1 mVA	±0.5% + 5 digits
	50.000 VA	0.001 VA	±1.0% + 10 digits
	500.00 VA ¹¹	0.01 VA	±1.0% + 10 digits
AC VA	250.00 uVA	0.01 uVA	±2.0% + 10 digits
	2500.0 uVA	0.1 uVA	±2.0% + 10 digits
	25000 uVA	1 uVA	±1.5% + 10 digits
	25.000 mVA	0.001 mVA	±1.5% + 10 digits
	250.00 mVA	0.01 mVA	±1.5% + 10 digits
	2500.0 mVA	0.1 mVA	±1.5% + 10 digits
	25000 mVA	1 mVA	±1.5% + 10 digits
	50.000 VA	0.001 VA	±2.0% + 20 digits
	500.00 VA ¹¹	0.01 VA	±2.0% + 20 digits

The TRMS bandwidth of the AC VA range is from 45 to 1 kHz.

This channel has overload protection for up to 600V.

Protection includes 440mA/1000V HRC Fuse 11A/1000V HRC Fuse.

¹¹ 500 VA, with 50 V and 10 A.

TEMPERATURE & CONTINUITY

	Range	Resolution	Accuracy
Temp °C	-200 to 1350°C K-Type	0.1°C	±0.5%+3°C
Continuity	30 Ω or 300 Ω User Selectable OPEN or CLOSED	10 mΩ	Not Specified

This channel has overload protection for up to 600 V.

External temperature measurement uses a K-Type thermocouple.

Internal temperature measurement is inside a sealed case, so will have some thermal lag.

The continuity tester can be set for beep on CLOSED or beep on OPEN (for wire breaks) with a user adjustable threshold level.

BLUETOOTH SPECIFICATIONS

- The 121GW uses a BLE112-A Class 2 certified Low Energy Bluetooth module.
- This device complies with Part 15 of the FCC Rules.
- This device complies with Industry Canada licence-exempt RSS standard(s).
- This device complies with Japan MIC certification ARIB STD-T66.

Contains Transmitter Module FCC ID: *QOQBLE112*

Contains Transmitter Module IC: *5123A-BGTBLE112*

The Bluetooth module is in conformity with the essential requirements and other relevant requirements of the CE RED(2014/53/EU).

The product is in conformity with the following standards and/or normative documents.

Essential Requirement	Applicable Standards / Specifications
Safety Requirements	EN 60950-1:2006+A11:2009+A1:2010+A12:2011+A2:2013
EMC Requirements	EN 301 489-1 V2.1.1 EN 301 489-17 V3.1.1
Radio Spectrum	EN 300 328 V2.1.1

The BLE112 Bluetooth module is KCC certified with following certification numbers:



- BLE112-A: *KCC-CRM-BGT-BLE112-A*
- BLE112-E: *KCC-CRM-BGT-BLE112-E*
- BLE112-N: *KCC-CRM-BGT-BLE112-N*

STANDARDS

This Multimeter complies to the following standards.

COMPLIANCE SYMBOLS

The device is marked with the following symbols, these have the following meanings:

Symbol	Definition
	RCM, this is the Regulatory Compliance Mark. It indicates that the product is compliant to required Australian Standards.
	CE, this is the Conformité Européenne mark. It indicates that the product complies with required European standards.
	ETL, the listed CUS Mark. It Indicates that the product is the mark that indicates testing by Intertek.

IEC STANDARDS

The product is Extra-Low voltage system, as per IEC 60038.

The product V_{AC} does not supply 50 or 120 V_{DC} .

The product is classified as IP41 as per IEC 60529 standards. Tested for IEC 60950-1 and IEC/EN61010-1: 2010 3rd Edition.

ANSI STANDARDS



Safety requirements tested as per ANSI 61010-1 and testing for hand-held equipment as per ANSI 61010-2.

CAT III rating as per ANSI. 61010-1.

SAFETY

This manual contains information and warnings that **must** be followed when operating the device. Following these instructions will protect you from damaging the device or risking your well-being. The device can only protect you up to a point and it should not be used in situations that do not comply with the devices ratings and the recommendations in this section.

The following symbols are used on the device and through this manual to indicate whether something is a warning or a precaution.

Symbol	Definition
	Caution: Possibility of electric shock
	Caution: See explanation in section

WARNING



A condition or action that could result in serious injury or death to the user.

1. Using the device outdoors risks electric shock or fire. The device is not designed to operate in rain or moisture.
2. The product is rated IP41 and should be treated accordingly. This means that the product should not be exposed to liquids or dust.
3. Inspect leads and ensure that no defects or damage exists on the leads, connectors or probes. Defective parts must not be used and need to be replaced before use.
4. Only use UL Listed Probe Assemblies with ratings that are greater or equal to the meter rating.
5. CAT III & CAT IV test probe tips must be 4 mm (As per IEC 61010-031).
6. All accessories must possess a greater than or equal to CAT rating to that of the Multimeter.

French:***Sécurité***

Ce manuel contient des informations et des avertissements qui doivent être suivis lors de l'utilisation de l'appareil. En suivant ces instructions, vous protégerez d'endommager l'appareil ou de risquer votre bien-être. L'appareil ne peut que vous protéger jusqu'à un certain point et ne doit pas être utilisé dans des situations qui ne sont pas conformes à la note des appareils et aux recommandations de cette section.

Les symboles suivants sont utilisés sur le périphérique et par le biais de ce manuel pour indiquer si quelque chose est un avertissement ou une précaution.

Symbole	Définition
	Attention: Possibilité de choc électrique
	Attention: voir l'explication dans la section

Attention

Une condition ou une action qui pourrait entraîner des blessures graves ou la mort de l'utilisateur.

1. L'utilisation de l'appareil à l'extérieur risque d'être électrique ou d'incendie. L'appareil n'est pas conçu pour fonctionner sous la pluie ou l'humidité.
2. Le produit est classé IP41 et devrait être traité en conséquence. Cela signifie que le produit ne doit pas être exposé aux liquides ou à la poussière.
3. Inspectez les câbles et assurez-vous qu'aucun défaut ou dommage n'existe sur les conducteurs, les connecteurs ou les sondes. Les

pièces défectueuses ne doivent pas être utilisées et doivent être remplacées avant utilisation.

4. N'utilisez que des ensembles de sonde homologués UL avec des valeurs nominales supérieures ou égales à celles du compteur.
5. Les pointes de la sonde de test CAT III et VAT IV doivent être de 4 mm (selon CEI 61010-031).
6. Tous les accessoires doivent posséder une valeur nominale supérieure ou égale à celle du multimètre.

CAUTION

A condition or action that could result in damage or malfunctions in the instrument.

1. **Before** changing functions, remove test leads from any measurement point.
2. **Before** any measurement, ensure test leads are connected to appropriate connector on the device and in an appropriate manner to the test points.











French:

Une condition ou une action pouvant entraîner des dégâts ou des dysfonctionnements dans l'instrument.

1. Avant de modifier les fonctions, retirez les fils de test de n'importe quel point de mesure.
2. Avant toute mesure, assurez-vous que les fils de test sont connectés au connecteur approprié sur l'appareil et de manière appropriée aux points de test.

OPERATION

The following section will outline how to operate the device. This section utilises some symbols which are defined in the table below:

 Dangerous Voltage	 Ground
 AC Alternating Current	 Warning or Caution
 DC Direct Current	 Double Insulation (Protection Class II)
 Either AC or DC	 Fuse
 Not Applicable to Identified Model	 Battery

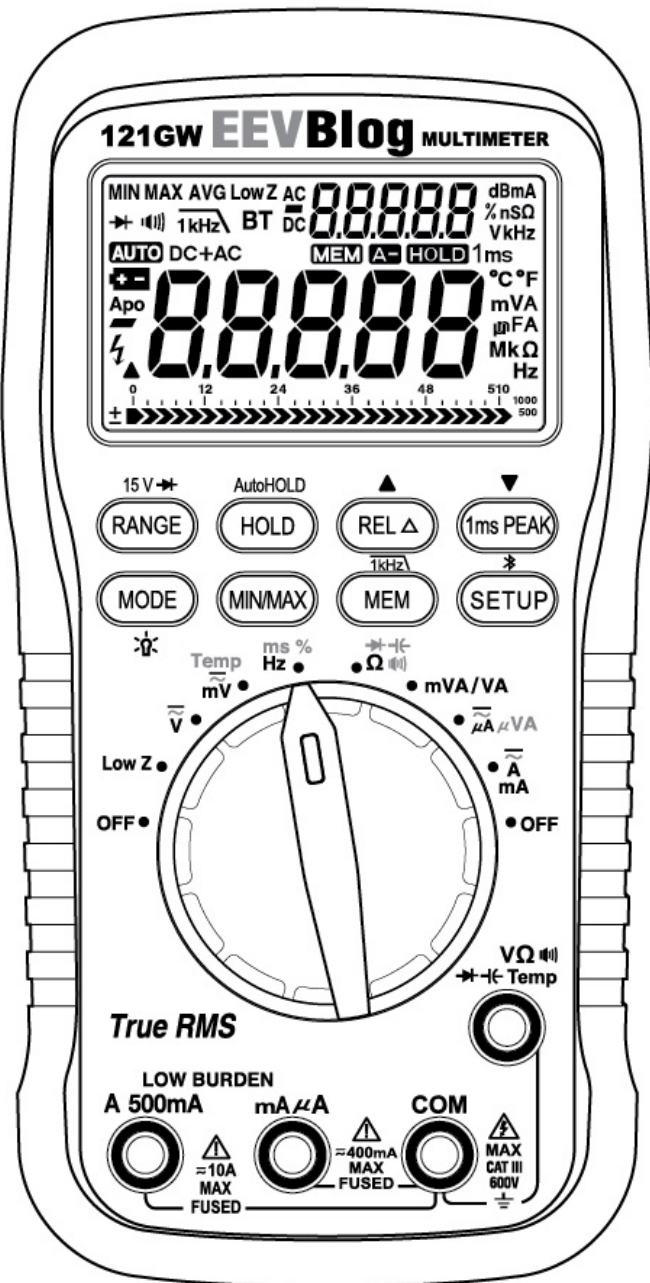



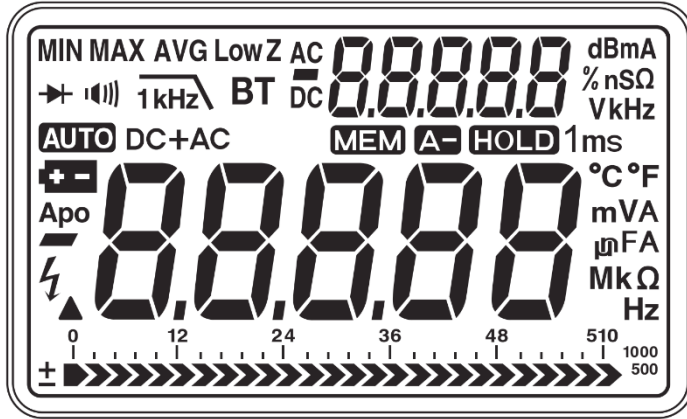



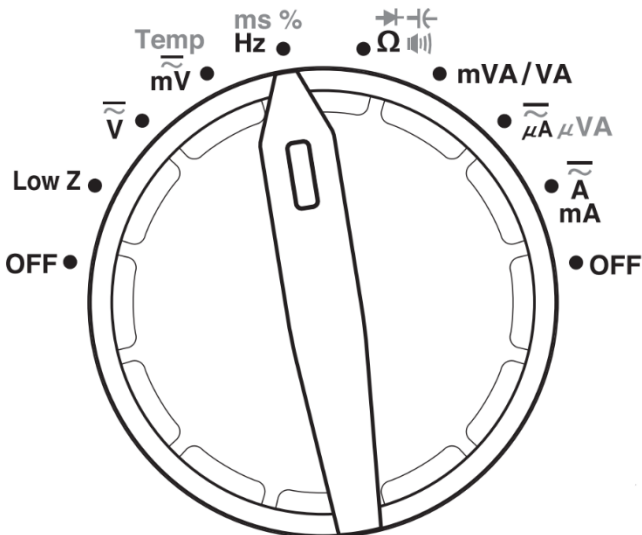

Digital Display: Readings are displayed on dual 4 1/2 -digit 50,000 count LCD display. One Primary and one smaller secondary function display. The secondary function display is only used when a function that requires it is selected. A fast updating bargraph is below the main display.



Rotary Switch: Used to turn the power off and on and select the test function. There are two OFF positions for convenience, both work identically.



-  **RANGE Button:** Used to swap between ranges of a function. This could be moving the decimal point for the voltage range, swapping between 3 V or 15 V diode mode etc...
-  **HOLD Button:** Used to select the Auto HOLD function
-  **REL Button:** Used to select the relative measurement mode. Secondary use as the *UP* arrow key for setup selection. Holding down this button in AC mode selects the 1 kHz low pass filter.
-  **1ms PEAK Button:** Used to select the 1 ms peak capture mode (VAC only). Secondary use as the *DOWN* arrow key for setup selection. Holding down this button turns on and off the Bluetooth data transfer functionality.
-  **MODE Button:** Used to select and cycle through the different function modes displayed in RED on the mode dial. Holding down this button will activate and deactivate the display backlight.
-  **MIN/MAX Button:** Cycles through and selects the *MIN*, *MAX*, and *AVG* measurement modes.
-  **MEM Button:** Holding down this button starts the SD card data logging. Pressing once allows viewing of the stored data.
-  **SETUP Button:** Displays the setup menu and cycles through the options. Press and hold the button when on the required option to edit that option.

A 500mA ***A / 500mA Jack:*** This input jack is used for the 10 A, 5 A and 500 mA current ranges. It is 11 A HRC fused. An input warning alert functions for this jack.



mA μ A ***mA / μ A Jack:*** This input jack is used for the 50 mA, 500 μ A and 50 μ A current ranges. It is 400 mA HRC fused. An input warning alert functions for this jack.



COM ***COM Jack:*** The negative common jack for all ranges and functions.



V Ω \rightarrow \leftarrow Temp ***V Ω Jack:*** The positive input jack used for voltage, resistance, capacitance, diode, continuity, and temperature functions. This input jack is PTC and MOV protected.



MEASURING

VOLTAGE $\overline{\sim}$ Temp $\overline{\sim}$ V $\overline{\sim}$ mV

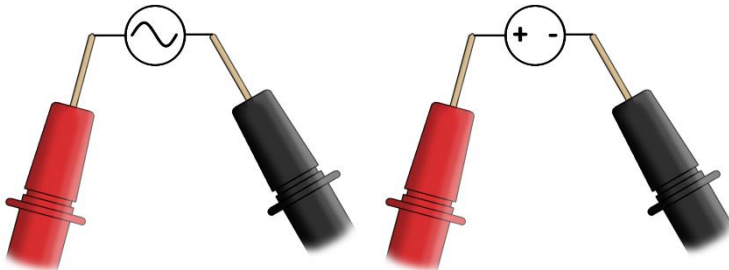
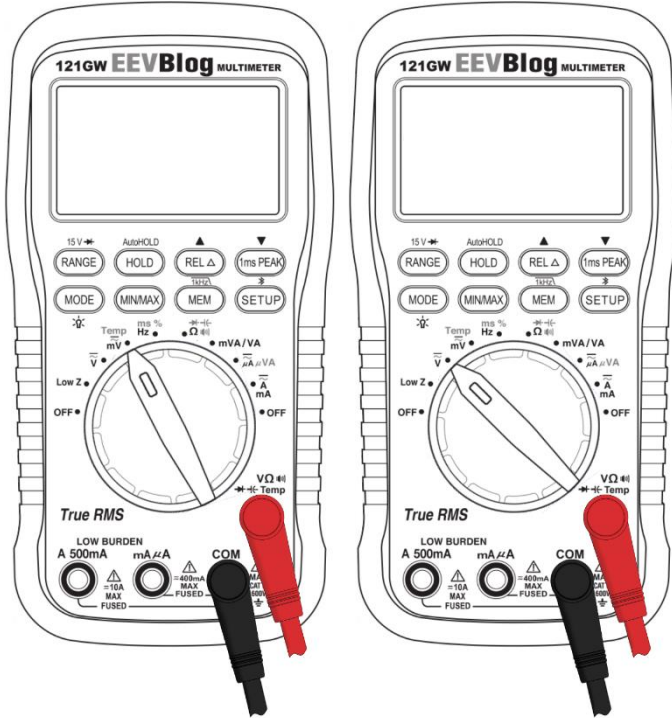

AC

When measuring AC voltages, you need to select the AC mode using the mode button. You will see the AC icon appear on the screen when you are in the correct mode.

In VAC mode, you can use the 1ms PEAK function, this will determine the maximum peak voltage, instead of the RMS voltage.

DC

To measure DC voltages, you must select the DC mode.

This is done by pressing the mode button. The DC icon will be shown on the screen when you are in the correct mode.

Modes

Pressing the *MODE* button will cycle through the following modes:

The following modes are available on the voltage range \tilde{V} :

1. DC
2. AC
3. DC+AC

The following modes are available on the millivolts range $\overset{\text{Temp}}{\tilde{mV}}$:

1. DC
2. AC
3. Temperature

dBm

In AC mode the multimeter supports standard dBm measurement to view this measurement press SETUP until the screen shows dBm in the top right.



The value of dBm is defined as follows, R_{REF} is by convention:

$$P = 10 \log_{10} \left(\frac{P}{P_0} \right) \quad P = \frac{V_{rms}^2}{R_{REF}} \quad R_{REF} = 600 \Omega \quad P_0 = 1 mW$$

$$\therefore dBm = 10 \log_{10} \left(\frac{V_{rms}^2}{600} \right) = 10 \log_{10} \left(\frac{5}{3} V_{rms}^2 \right)$$

VOLTAGE Low Z

The Low Z mode of the multimeter is vastly different to the VAC mode. The mode provides a means of draining ghost-voltages. The impedance of this range is particularly low when compared to other ranges.

The range connected to ground through 1K resistor and a 1.2K PTC.

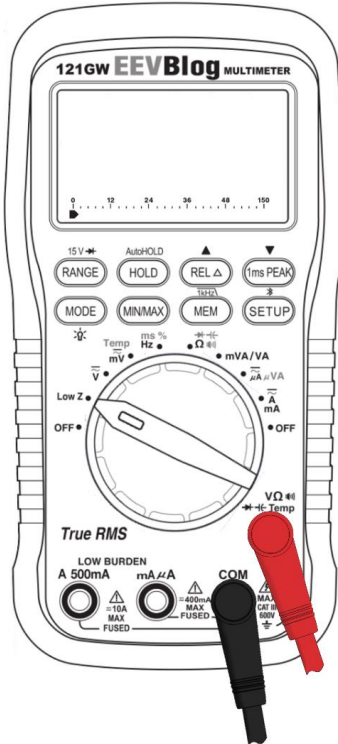

This range is used in the same manner to the VAC mode.

The range is not designed to be operated at low voltages (below 12V), it is also not designed for high frequencies. This range is typically used between 50Hz and 400Hz.

TEMPERATURE $\frac{\text{Temp}}{\text{mV}}$



When measuring temperature be sure to have the leads connected as above and in the correct range.

To enter the temperature mode, press the mode button twice after selecting mV on the dial.

CURRENT \tilde{A} mA μA μVA

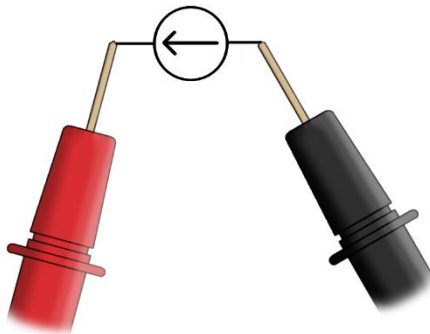
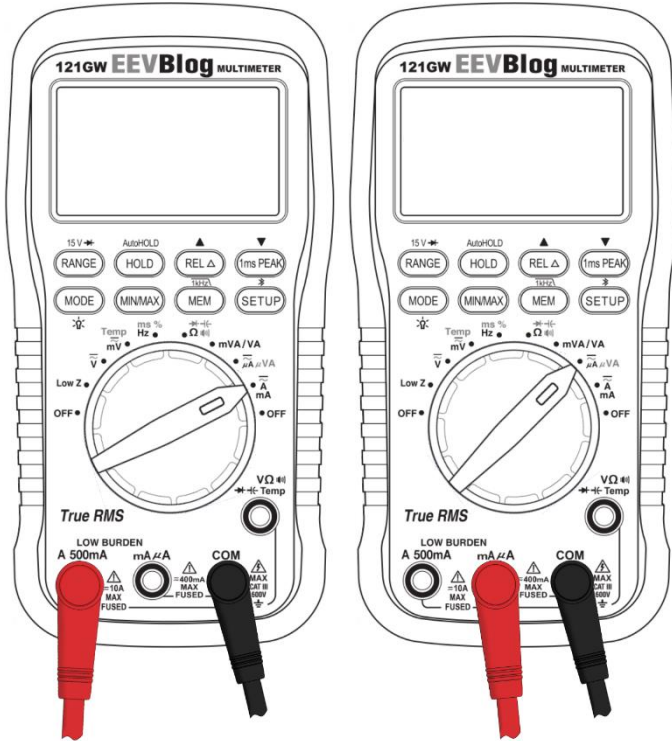

When measuring current be sure to have the leads connected as above and in the correct range, for higher currents ensure that the red lead is connected to the A 500 mA socket.

AC

When measuring AC current, you must press the mode button until the AC icon appears on screen.

DC

The default mode will be DC measurement. If the DC icon is not shown on the screen press the mode button until it is.

Modes

Pressing the *MODE* button will cycle through the following modes:

The following modes are available on the amp/milliamp range $\overset{\sim}{\mu\text{A}}$ mA:

1. DC
2. AC



The following modes are available on the microamp range $\overset{\sim}{\mu\text{A}}$ μVA :

1. DC
2. AC

BURDEN VOLTAGE

When measuring current on the multimeter there is a voltage drop across the resistor used to measure the current. This voltage is called the “burden voltage”.

To enable or disable the burden voltage measurement, perform the following steps:

1. Press and hold , until bd.XXX flashes.
2. Press UP or DOWN to toggle on or off the burden voltage.
3. Press and hold , until bd.XXX no longer flashes.
4. Press  again to display the burden voltage on the secondary display.

To measure the burden voltage an additional lead is required, this must be connected between the active current terminal and the voltage input, as shown below:

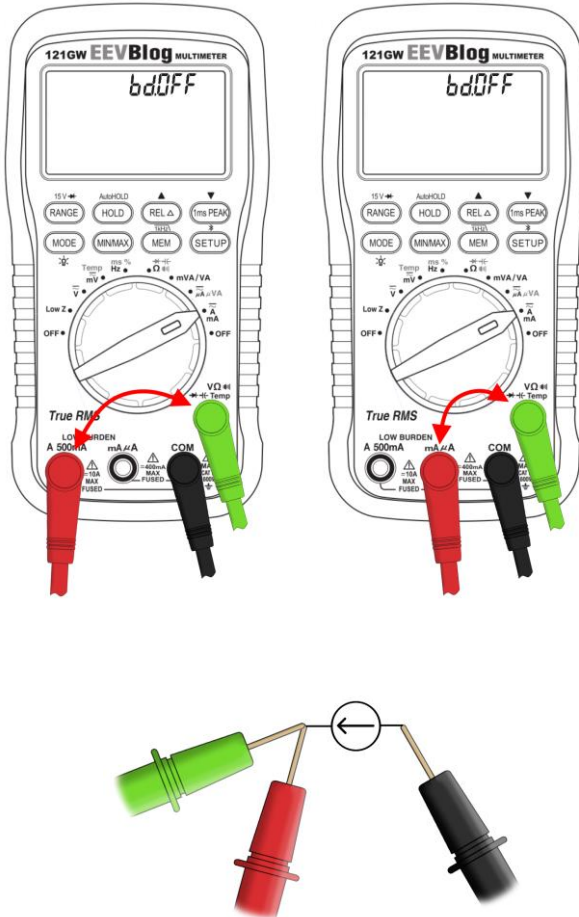

RESISTANCE Ω 

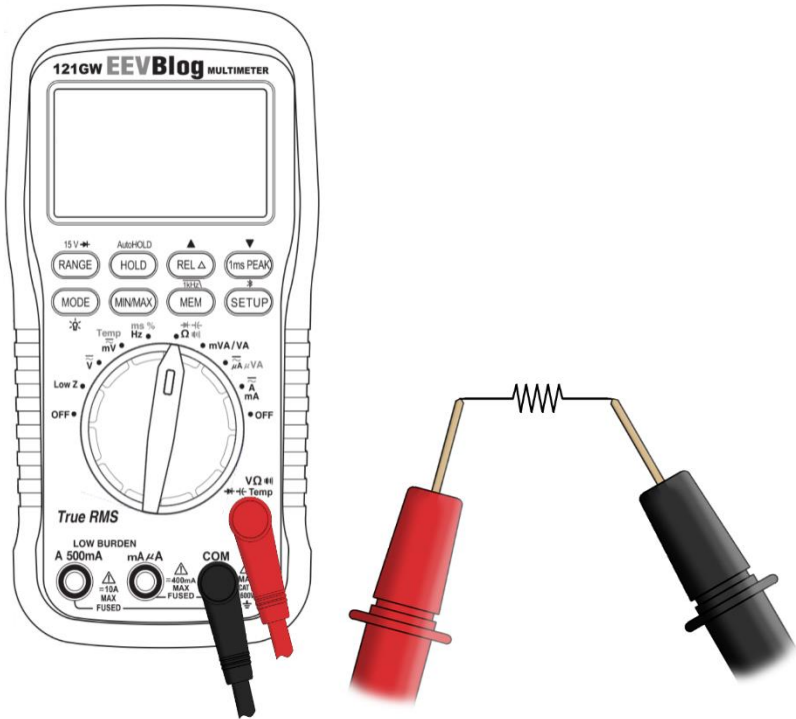

When measuring resistance select the range as shown above with the leads connected as shown above.

Resistance is measured between the two leads.

Modes 

Pressing the *MODE* button will cycle through the following modes:

The following modes are available on the resistance range Ω  :

1. Resistance
2. Continuity tester
3. Diode tester
4. Capacitance measurement

CONTINUITY TESTING 

When taking measurements, you must connect the leads as shown above.

To check if a short (Selectable $<30\ \Omega$ or $<300\ \Omega$) exists you can use the continuity tester. To use this range, you need to press the *MODE* button once. To change the continuity threshold level between $>30\ \Omega$ or $>300\ \Omega$, select the Continuity mode and:

1. Press *SETUP* until “UP xxx” or “dN xxx” appears on the small display.
2. Hold *SETUP* to change the mode.
3. Press the *UP* and *DOWN* buttons to toggle between continuity testing mode and cable break testing mode. Continuity mode is the “dN” mode, and you can select either **dN 30** or **dN 300** for $30\ \Omega$ or $300\ \Omega$ respectively.
4. Hold *SETUP* to store the required mode (Until it beeps).

CABLE BREAK TESTING 

When taking measurements, you must connect the leads as shown above.

To check if a break exists (Selectable $> 30 \Omega$ or $> 300 \Omega$) you can use the cable break tester. To use this range, you need to select the Continuity mode and:

1. Press *SETUP* until “UP xxx” or “dN xxx” appears on the small display.
2. Hold *SETUP* to change the mode.
3. Press the *UP* and *DOWN* buttons to toggle between continuity testing mode and cable break testing mode. Cable break mode is the “UP” mode, and you can select either **UP 30** or **UP 300** for 30Ω or 300Ω respectively.
4. Hold *SETUP* to store the mode (Until it beeps).

CAPACITANCE



When taking measurements, you must connect the leads as shown above.

To enter the capacitance mode, press the *MODE* button three times.

You can zero out the residual lead and meter capacitance with the *REL* function.

Ensure that the capacitor is discharged before measurement.

FREQUENCY ^{ms %}
Hz



When taking measurements, you must connect the leads as shown above.

Frequency measurement is the default mode for the dial position shown above.

Modes 

Pressing *MODE* will result in a change in the measurement mode

The following modes are available on the frequency range ^{ms %} Hz :

- 1. Frequency
- 2. Pulse width
- 3. Duty Cycle

DUTY CYCLE $\frac{\text{ms \%}}{\text{Hz}}$



When taking measurements, you must connect the leads as shown above.

To enter the duty cycle mode press mode twice after selecting the Hz dial position.

PERIOD $\frac{ms}{Hz}$ %



When taking measurements, you must connect the leads as shown above.

To enter the period measurement mode press *MODE* once after selecting the Hz dial position. The period in milliseconds will be displayed.

DIODE MEASUREMENT



When taking measurements, you must connect the leads as shown above.

The diode measurement range also supports a high voltage mode (up to 15 V) that enables the measurement of Zener voltages, LED string arrays and other similar potentials.

The output current is limited by the nominal 2.2 k Ω total PTC + Resistor protection devices, and the voltage mode selected. It is not a constant current generator, so take this into account when measuring devices.

Voltage mode is toggled between 3 V and 15 V by pressing the RANGE button after selecting the diode measurement mode, the secondary display will then show the maximum diode voltage measurable.

The voltage range is displayed on the secondary display as follows:

]

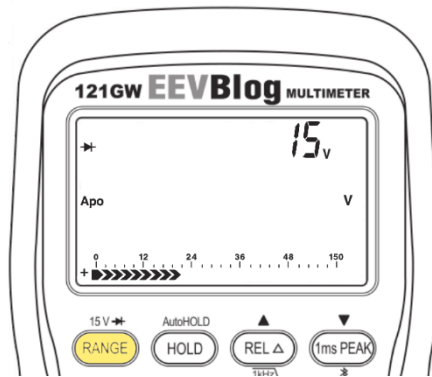

POWER (VA) mVA/VA $\mu A/\mu VA$

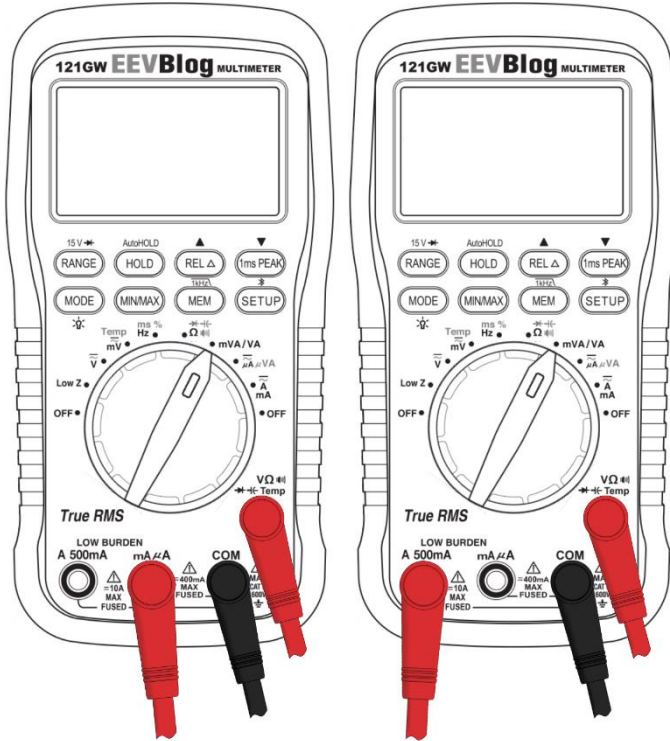

Power measurements require measurements of both voltage and current, be careful to connect the system in a manner that the common terminal is common for both the voltage measurement and the current measurement.

An example is shown below:

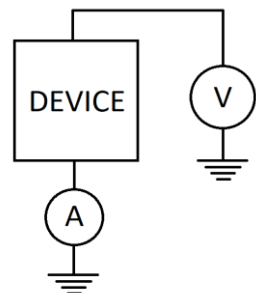

DATA LOGGING

Data logging is started by holding the *MEM* button until a beep is heard and the *MEM* icon flashes on screen.



Logged data is stored to an internal Micro SD card which is accessible behind the battery cover. Data is by default recorded once per second.

The logging data is stored on the SD card in the following format as a CSV:

	Main			Secondary		
Sample	Function	Value	Units	Function	Value	Units
1	DCV	0.0000	V	etc.	etc.	etc.

The data that is recorded is taken from the currently displayed function, if you are measuring voltage then voltage is recorded. The number of accumulated logged data points is displayed on the secondary display.

To stop data logging press and hold the *MEM* button.

BACKLIGHT



To enable the backlight, hold the *MODE* button.

BLUETOOTH

To enable Bluetooth communications, hold the “1ms PEAK” button until BT is displayed on the LCD.

Ensure that Bluetooth is enabled on the host device before running the application on the remote computing device.

The multimeter will continue to functional as normal in Bluetooth mode, but the display data will be transmitted via the Bluetooth connection.

To disable Bluetooth mode press and hold the 1ms Peak button until BT is not displayed.

MEASUREMENT HOLD

There are two measurement HOLD functions.

1. *Manual Hold*

To pause the measurement on the main display, press the *HOLD* button. To resume measurement, you need to press the button again until *A-* and *HOLD* are no longer visible.

The bargraph display will continue to update in “live” mode while the captured value is held on the screen.

2. *Automatic Hold*

Press the *HOLD* button twice until *A-HOLD* is displayed.

This mode will wait for a stable reading and automatically lock that value on the display. A beep will be heard to indicate this capture.

It will continue to hold this value until the measurement changes significantly and a new stable reading is found. This mode is great for when you must keep your hands on the probes.

RELATIVE MEASUREMENT (REL)

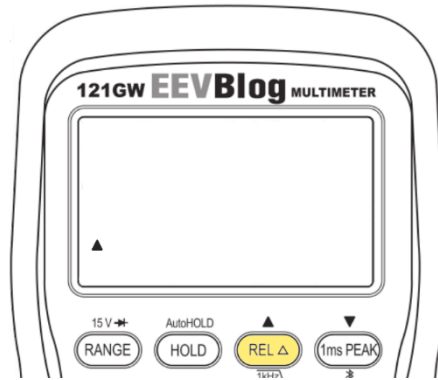

If you are measuring something relative to another measurement or need to calibrate any non-zero error out you can press the *REL* button to zero, the currently displayed value.

All subsequent measurements will have this stored relative value subtracted from the result. The displayed measurement is the difference between the actual measured value and the stored relative value.

It is useful for example to cancel out the resistance of test probes in the ohms range.

MIN/MAX/AVG

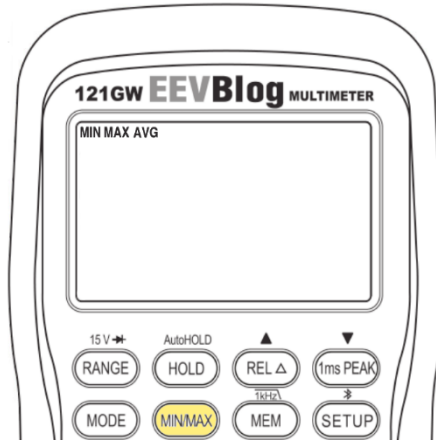

To find the minimum and maximum value found during sampling you can use the *MIN/MAX* button.

This button also provides an average function *AVG*. This can be entered by pressing the button until the *AVG* symbol appears.

To capture min, max and average results press the *MIN/MAX* button until all three icons are shown on the LCD.

To exit out of these modes hold the button until a beep is heard, and the icons are cleared from the screen.

Pressing the *MIN/MAX* button will cycle through the displayed results of each measurement.

SETUP MENU

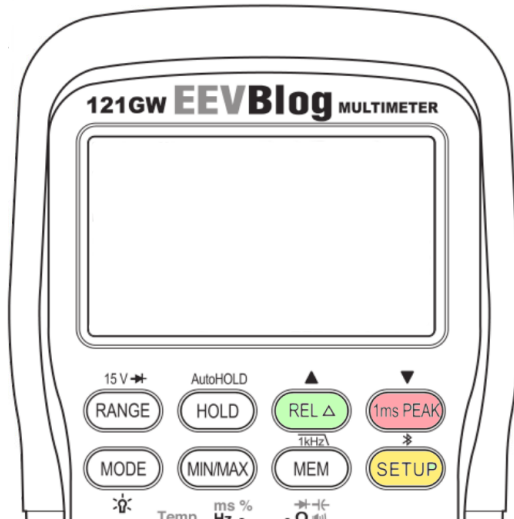

To configure and read settings for the multimeter you can press the *SETUP* button to view the settings. If you press the setup button multiple times you will cycle through the menu, the order of the menu is as follows:

1. Temperature
2. Battery Voltage
3. Auto Power Off (APo)
4. Buzzer On/Off (b-Off)
5. LCD Contrast
6. Year
7. Month-Day
8. Hour-Minute
9. Multimeter ID
10. Logging Interval (In 0)
11. Additional settings dependent upon the function selected.

TEMPERATURE

The multimeter has an internal temperature which can be used for rough ambient temperature measurement. Note that there will be thermal lag due to the sealed enclosure. It is displayed on the secondary display.

The displayed temperature can be changed from Celsius to Fahrenheit using the SETUP menu. To do this:

1. Navigate to the temperature item using SETUP.
2. Press and hold *SETUP*, until display flashes.
3. Use the *UP/DOWN* arrow keys to toggle between “c” and “F”.
4. To save the setting press and hold *SETUP*, until display no longer flashes.

BATTERY VOLTAGE

To check the status of the batteries in the multimeter press the SETUP button until “bAt” is displayed. The Low Battery icon will activate when the battery voltage falls below approximately 4.2 V

It is recommended that you change the battery when the battery icon is displayed, as the unit’s specifications are no longer guaranteed.

Lithium batteries have a higher voltage and may cause the device to malfunction. Alkaline batteries are recommended.

AUTO POWER OFF (APO)

With some measurements you may not want the multimeter to automatically power off (After 30 minutes). To disable automatic power off:

1. Navigate to the APo menu item using SETUP.
2. Press and hold *SETUP*, until display flashes.
3. Press *UP/DOWN* to toggle between “APO.oN” and “APO.oF”.
4. To save the setting press and hold *SETUP*, until display no longer flashes.

APO is disabled in data logging mode.

BUZZER ON/OFF

If you wish to disable/enable the buzzer to perform the following steps:

1. Navigate to the b-OFF or b-ON menu item using the *SETUP* button.
2. Press and hold *SETUP*, until display flashes.
3. Press *UP/DOWN* to toggle between “b-OFF” and “b-ON”.
4. To save the setting press and hold *SETUP*, until display no longer flashes.

LCD CONTRAST

If the multimeter has ghosted characters you may want to turn the contrast down, if the screen is not dark enough you may need to turn up the contrast.

This may need to be changed due to variations in ambient operating temperature.

To change the contrast:

1. Navigate to the menu item that says LCD X using the *SETUP* button.
2. Press and hold *SETUP*, until display flashes.
3. Press *UP* and *DOWN* to configure the screen contrast, change until the screen contrast is as desired.
4. To save the setting press and hold *SETUP*, until display no longer flashes.

DATE

There are three menu items that can be used to read and set the currently configured date. These are the following menu items:

1. Year “YYYY”
2. Month-Day “MM-DD”
3. Hour-Minute “HH-mm”

To change the date items:

1. Navigate to the menu item.
2. Press and hold *SETUP*, until display flashes.
3. Press *UP* and *DOWN* to configure the date/time item.
4. To save the setting press and hold *SETUP*, until display no longer flashes.

MULTIMETER ID

This is a user configurable ID which is used to differentiate between multiple 121GW units. This value is what appears in the App and can be changed by doing the following:

1. Navigate to the menu item “XXXXX” using SETUP (Where X are numbers)
2. Press and hold *SETUP*, until display flashes.
3. Press UP and DOWN keys to configure the value.
4. Hold SETUP until a beep is heard to save the value.

LOGGING INTERVAL

The logging interval can range from 200 ms to 999 seconds. If you need to change the interval, then you should:

5. Navigate to the menu item “In x” using SETUP.
6. Press and hold *SETUP*, until display flashes.
7. Press UP and DOWN keys to configure the time interval in seconds.
If “x” is set to zero, the sample rate will be set to the ADC’s maximum rate (approximately 200 ms).
8. Hold SETUP until a beep is heard to save the value.

MAINTENANCE

The 121GW maintenance is outlined in this section.



Before opening case for maintenance, disconnect test leads from the meter and turn off the meter.

DEBUGGING

1. If a low battery alert appears on the device as indicated in the operation section, the back of the device must be opened to replace the AA batteries.
2. If the measurements fail to respond to changes in measured devices check the fuse, leads and test probe connections.

CLEANING AND STORAGE

The device should be kept in a clean condition, this requires periodic cleaning. The device should be cleaned slightly damp cloth with mild detergent. Do not use solvents or abrasives as they could damage the device.

When the device is placed into long term storage (>50 days) the batteries should be removed to reduce the risk of leakage or unnecessary drain.

FUSE REPLACEMENT

To check whether you need to replace a fuse perform the following steps:

1. Switch to the voltage range and connect a lead as shown in the below diagram.
2. If the multimeter beeps the fuse is functioning, if it fails to beep it indicates that the fuse is blown.

If it fails to beep when connected to the “A” jack, then it is likely that the larger A fuse is blown.

If it fails to beep when connected to the “mA” jack, then it is likely that the smaller mA fuse is blown.

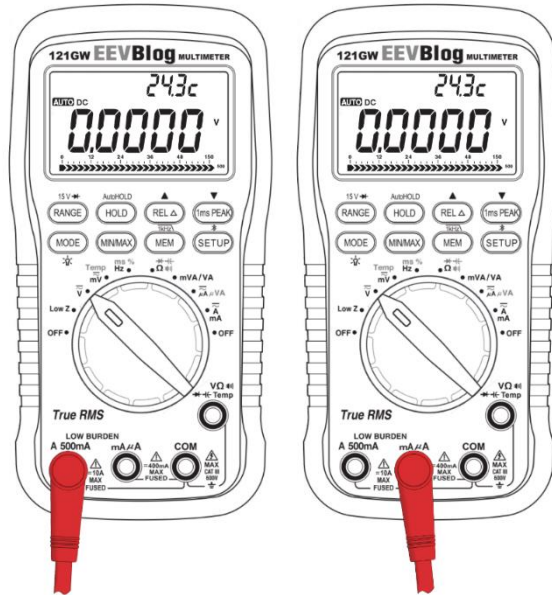

- mA/μA current input fuse: 400 mA / 600 V DC/AC, IR 10 kA HRC FAST
- Designed to UL 248-1
- Dimension: 6mm x 32 mm
- Recommended: ASTM HV610.0.4 400 mA (600V) or HV620.0.4 (1000V)
- A/500 mA current input fuse: 11 A/1000 V DC/AC, IR 20 kA HRC FAST
- Dimension: 10mm x 38 mm 5AG
- Recommended: ASTM HV110.11A, Bussmann DMM-B-11A, or Little-fuse FLU011

CALIBRATION

WARNING:

Entering the calibration mode can render your unit non-operational or out of specification. Factory calibration will be VOID if this function is used. This mode is only intended for those with the experienced knowledge and equipment necessary to calibrate their own equipment.

The calibration procedure can be performed for only one, or all desired ranges and functions. When complete, re-power the meter to exit calibration mode.

It is possible to recalibrate a single range and function if desired, there is no need to calibrate all ranges once started.

The calibration values are stored in EEPROM and are not affected by firmware updates.

CALIBRATION MODE

To enable calibration mode the following procedure must be followed:

1. Turn off the meter
2. Press and hold the MODE button.
3. Turn on device.
4. If the screen says, "CAL 1". Press REL button, enter calibration mode.
5. The secondary screen will display "CAL" when the device is in calibration mode.
6. Switch to the function mode you want to calibrate as per normal meter operation. (voltage, current, resistance etc)
7. Press the RANGE button to enter the range you need to calibrate. To double check the current range notice the SI units displayed and the position of the decimal point. Calibrating the incorrect range could ruin your day.
8. After selecting the range and mode you can perform calibration, see next section.

NOTE: Calibration should be performed in this order:

1. Offset calibration
2. Scale calibration

SAVING CALIBRATION DATA

To backup calibration data you can perform the following procedure:

1. Ensure an SD card is in the multimeter.
2. Hold MEM.
3. Turn on the meter.
4. Release MEM.
5. Press the UP button.
6. Press the Mode button.
7. The calibration data will now be saved to the SD card.

LOADING CALIBRATION DATA

To load calibration data from SD card you can perform the following procedure:

8. Ensure an SD card is in the multimeter.
9. Hold MEM.
10. Turn on the meter.
11. Release MEM.
12. Press the DOWN button.
13. Press the Mode button.
14. The calibration data will now be loaded from the SD card.

ZERO OFFSET CALIBRATION

To calibrate the offset of a mode and range the following procedure must be followed:

1. Follow the steps shown in the section “Calibration Mode”.
2. Disconnect or short the input that would result in a zero reading as required for that function:



Mode	Action
Low Z	N/A
Voltage DC	Short Inputs
Voltage AC	10% of full Scale
Current DC	Open Circuit
Current AC	10% of full scale
Resistance	Short Inputs with Low Z Shunt
Temperature	Pending Procedure
Frequency	N/A

3. Press the SETUP button to begin offset calibration
4. Hold your breath, cross your fingers, and don't make any sudden movements that could frighten the meter. Beard stroking is allowed.
5. There will be a timer countdown. When the timer reaches zero the zero-offset calibration will complete and will be stored.

NOTE: If you do not setup the leads prior to starting the offset calibration then the final calibration value will be affected. If at any time during the timer countdown the measurement is interrupted the offset calibration procedure should be restarted.

FULL SCALE GAIN CALIBRATION

Before attempting any full-scale gain calibration, you need to be sure that you have the required reference values for the ranges that calibration is needed. These values are given in the calibration table.

To calibrate the full-scale gain of a range the following procedure must be followed:

1. Follow the steps shown in the section “Calibration Mode”.
2. Connect a reference generator with the test parameter value as outlined in the following calibration table for the specific range. Ensure that appropriate and desired uncertainty and traceability conditions are met.
3. Hold your breath, cross your fingers, and don't make any sudden movements that could frighten the meter or calibration equipment. Beard stroking is allowed.
4. Press the MEM button to begin gain calibration.
5. There will be a timer countdown. When the timer reaches zero the gain calibration will complete and will be stored.



NOTE: If you do not setup the leads prior to starting the offset calibration then the final calibration value will be affected. If at any time during the timer countdown the measurement is interrupted the offset calibration procedure should be restarted.

CALIBRATION REFERENCE TABLE

Calibration Procedures & Button Operations													
IAP Mode Start : Press "HOLD & MEN" button when turning the Meter on, and then press "SETUP" button													
Cal Mode Start : Press "MODE" button when turning the Meter on, and then press "RANGE" button													
Cal Mode KEY : OFFSET : "SETUP", GAIN : "MEM", Thermistor 23°C : "MEM" Long (1.5sec)													
Range	R0	R1	R2	R3	R4	R5	R6	OFFSET	GAIN	Mode			
0 Low-Z	600.00V	* "REC" & "Manual" features are not av ^l							x	X			
1 DCV	5.0000V	50.000V	500.00V	600.0V				0V	All	AD1			
2 ACV	5.0000V	50.000V	500.00V	600.0V				10%	All	RWS/AD2			
PeakHold	+ACmV & ACV : Calibrate 0.3V Offset & 3V Gain at AC5V Rsp							0.3V @5V	3V @5V	PEAK			
3 DCmV	50.000mV	500.00mV						0mV	All	AD1			
4 ACmV	50.000mV	500.00mV						10%	All	RWS/AD2			
5 Temp.	200.0° C ~ 1350.0° C						NTC 23°C	0mV:NTC Temp.	50mV 1233.5°C + NTC Temperature	TC:AD1 TR:WPU			
6 Hz/mS/%	99.999Hz	999.99Hz	9.999 KHz	99.999 KHz	999.99 KHz			x	150KHz	CNT			
7 Resistor	50.000Ω	500.00Ω	5.0000 KΩ	50.000 KΩ	500.00 KΩ	5.0000 MΩ	50.000 MΩ	0Ω	R0-R5: 50000 R6: 40.000MΩ	AD1			
8 Beep	500Ω	Under30Ω /Over30Ω /Under300Ω /Over 300Ω							0Ω	500Ω	AD1		
9 Diode	3.0V	3V / 15V Selectable						x	3.0V	AD1			
10 Capacitor	10.00nF	100.0nF	1.000 uF	10.00 uF	100.0 uF	10.00 mF		R1 :	R0-R4: 1000 R5: 1mF Gain	CNT			
11 ACuVA	(50uA*50V) 2500.0uVA	(500uA*50V) 25000uVA	at 50Hz						0	50uA*50V/50Hz 500uA*50V/50Hz	RWS/AD2		
12 ACmVA	(5mA*50V) 250.00mVA	(50mA*50V) 2500.0mVA									0	5mA*50V/50Hz 50mA*50V/50Hz	RWS/AD2
13 ACVA	(500mA*50V) 25000mVA	(10A * 50V) 500.00VA									0	500mA*50V/50Hz 10A*50V/50Hz	RWS/AD2
14 ACuA	50.000uA	500.00uA									10%	All	RWS/AD2
15 DCuA	50.000uA	500.00uA						0	All	AD1			
16 ACmA	5.0000mA	50.000mA						10%	All	RWS/AD2			
17 DCmA	5.0000mA	50.000mA						0	All	AD1			
18 ACA	500.00mA	5.0000A	10.000A					10%	All	RWS/AD2			
19 DCA	500.00mA	5.0000A	10.000A					0	All	AD1			
20 DCuVA	(50uA*50V) 2500.0uVA	(500uA*50V) 25000uVA						0	50uA*50V 500uA*50V	AD1			
21 DCmVA	(5mA*50V) 250.00mVA	(50mA*50V) 2500.0mVA						0	5mA*50V 50mA*50V	AD1			
22 DCVA	(500mA*50V) 25000mVA	(10A * 50V) 500.00VA						0	500mA*50V 10A*50V	AD1			

FIRMWARE UPDATE

The 121GW features updatable firmware that enables upgrades to be performed by the user from the SD card. To perform a firmware update, follow the following procedure:

1. Turn off the multimeter.
2. Insert an SD card into the multimeter with the latest EEVblog.bin firmware file.
3. Press and hold the **HOLD** and **MEM** buttons simultaneously.
4. Switch on the multimeter.
5. "IAP" will appear on the screen, then press **SETUP** to enter firmware upgrade mode.

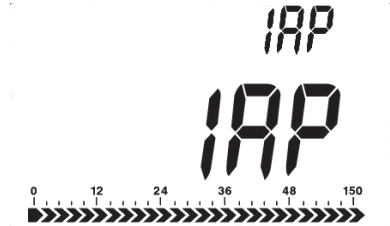

6. The multimeter will restart itself once the update is complete, do not do this manually.

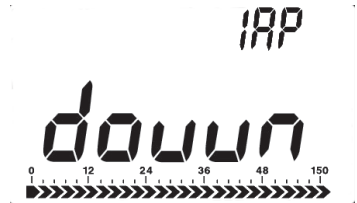

NOTE: Do not disconnect the SD card or power down the multimeter until the upgrade is complete. The bootloader should be robust enough to handle this, but just don't, ok!

WARRANTY

The 121GW is warranted to be free from defects in materials and workmanship for a period of one year from the date of purchase. If within the warranty period your instrument should become inoperative from such defects, the unit will be repaired or replaced at the company's option.

This warranty covers normal use and does not cover damage which occurs in shipment or failure which results from alteration, tampering, hacking, accident, misuse, abuse, neglect or improper maintenance.

Batteries and consequential damage resulting from failed batteries are not covered by warranty.

Any implied warranties, including but not limited to implied warranties of merchantability and fitness for a purpose, are limited to the express warranty. The company shall not be liable for loss of use of the instrument or other incidental or consequential damages, expenses, or economic loss, or for any claim or claims for such damage, expenses or economic loss.

A purchase receipt or other proof of original purchase date will be required before warranty repairs or replacement will be rendered.