

AC VOLTMETER

400GL

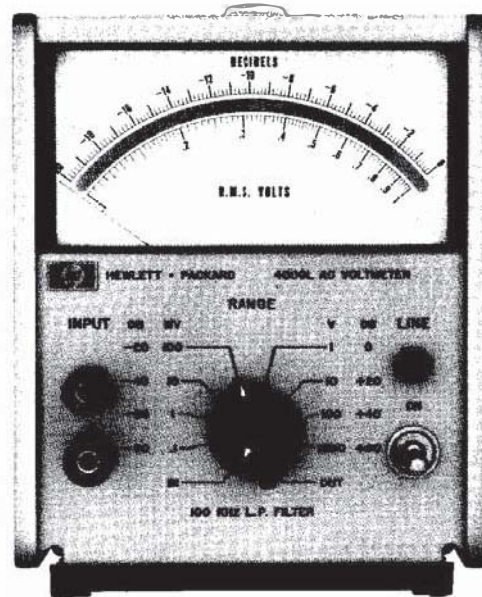

HEWLETT  PACKARD

HP 400GL

September '69



CERTIFICATION

The Hewlett-Packard Company certifies that this instrument was thoroughly tested and inspected and found to meet its published specifications when it was shipped from the factory. The Hewlett-Packard Company further certifies that its calibration measurements are traceable to the U.S. National Bureau of Standards to the extent allowed by the Bureau's calibration facility.

WARRANTY AND ASSISTANCE

All Hewlett-Packard products are warranted against defects in materials and workmanship. This warranty applies for one year from the date of delivery, or, in the case of certain major components listed in the operating manual, for the specified period. We will repair or replace products which prove to be defective during the warranty period. No other warranty is expressed or implied. We are not liable for consequential damages.

For any assistance contact your nearest Hewlett-Packard Sales and Service Office. Addresses are provided at the back of this manual.



OPERATING AND SERVICE MANUAL

(HP PART NO. 00400-90008)

MODEL 400GL
AC VOLTMETER

SERIALS PREFIXED: 628-, 737-, 943-

See MANUAL BACKDATING CHANGES Appendix C

Copyright Hewlett-Packard Company 1966
P. O. Box 301, Loveland, Colorado, 80537 U. S. A.

TABLE OF CONTENTS

<p>Section</p> <p>I GENERAL INFORMATION 1-3</p> <p>1-1. Description 1-3</p> <p>1-5. Accessory 1-3</p> <p>1-7. Instrument and Manual Identification . 1-3</p> <p>Section</p> <p>II INSTALLATION 2-1</p> <p>2-1. Introduction 2-1</p> <p>2-3. Initial Inspection 2-1</p> <p>2-5. Power Requirements 2-1</p> <p>2-7. Grounding Requirements 2-1</p> <p>2-10. Installation 2-1</p> <p>2-12. Bench Mounting 2-1</p> <p>2-14. Rack Mounting 2-1</p> <p>2-16. Combination Mounting 2-1</p> <p>2-18. Repackaging for Shipment 2-1</p> <p>Section</p> <p>III OPERATING INSTRUCTIONS 3-1</p> <p>3-1. Introduction 3-1</p> <p>3-3. Controls, Indicators and Connectors . 3-1</p> <p>3-5. Turn On Procedures 3-1</p> <p>3-6. DB Measurements 3-1</p> <p>3-7. AC Voltage Measurements 3-1</p> <p>3-8. Wide Band AC Amplifier 3-2</p> <p>Section</p> <p>IV THEORY OF OPERATION 4-1</p> <p>4-1. General 4-1</p> <p>4-3. Block Diagram Description 4-1</p> <p>4-5. Schematic Theory 4-1</p> <p>4-7. Input Attenuator 4-1</p> <p>4-9. Preamplifier 4-1</p> <p>4-13. Post Attenuator 4-1</p> <p>4-15. 100 KHz Low Pass Filter 4-1</p> <p>4-17. Meter Amplifier 4-1</p> <p>4-22. Meter Bridge 4-2</p> <p>4-27. Power Supply 4-2</p>	<p>Section</p> <p>V MAINTENANCE 5-1</p> <p>5-1. Introduction 5-1</p> <p>5-3. Test Equipment Required 5-1</p> <p>5-5. Performance Checks 5-1</p> <p>5-10. Top Cover Removal 5-1</p> <p>5-12. Accuracy and Frequency Response Checks 5-1</p> <p>5-18. Range Tracking Check 5-2</p> <p>5-20. Input Impedance Check 5-3</p> <p>5-23. Alignment and Calibration Procedures . 5-4</p> <p>5-25. Cover Removal and Replacement . . 5-4</p> <p>5-30. Meter Calibration 5-5</p> <p>5-34. Attenuator Alignment 5-5</p> <p>5-36. A 2Q1 Bias Adjustment 5-5</p> <p>5-38. Replacement of A2C 37* 5-5</p> <p>5-41. Troubleshooting Procedure 5-5</p> <p>5-46. Power Supply 5-6</p> <p>5-48. Amplifiers 5-6</p> <p>5-50. Meter Bridge 5-7</p> <p>5-52. Etched Circuit Board Repair 5-7</p> <p>Section</p> <p>VI CIRCUIT DIAGRAMS 6-1</p> <p>6-1. Introduction 6-1</p> <p>Section</p> <p>VII REPLACEABLE PARTS 7-1</p> <p>7-1. Introduction 7-1</p> <p>7-4. Ordering Information 7-1</p> <p>7-6. Nonlisted Parts 7-1</p> <p>Appendix</p> <p>A CODE LIST OF MANUFACTURERS</p> <p>Appendix</p> <p>B SALES AND SERVICE OFFICES</p>
--	--

LIST OF TABLES

<p>Number</p> <p>1-1. Specifications 1-2</p> <p>3-1. Effect of Distortion on Average Respond- ing Meter 3-2</p> <p>3-2. AC Amplifier Gain Factors 3-2</p> <p>5-1. Test Equipment 5-0</p> <p>5-2. Meter Calibration Tolerances 5-3</p>	<p>Number</p> <p>5-3. Range Tracking Tolerances 5-3</p> <p>5-4. Troubleshooting Guide 5-6</p> <p>5-5. Power Supply Voltages 5-6</p> <p>5-6. Preamplifier Voltages 5-6</p> <p>5-7. Meter Amplifier Voltages 5-6</p> <p>5-8. Meter Bridge Voltages 5-7</p> <p>7-1. Replaceable Parts 7-2</p>
--	---

LIST OF ILLUSTRATIONS

<p>Number</p> <p>1-1. Model 400GL AC Voltmeter 1-0</p> <p>1-2. Model 11074A Voltage Divider Probe . . . 1-1</p> <p>1-3. Model 11076A Instrument Case 1-1</p> <p>3-1. Location of Controls and Indicators 3-0</p> <p>3-2. External Battery Connection 3-1</p> <p>4-1. Functional Circuit Diagram 4-0</p> <p>4-2. Filter Attenuation Characteristics 4-1</p> <p>4-3. Simplified Diagram of Metering Circuit . 4-2</p> <p>5-1. Accuracy and Frequency Response Check . 5-0</p>	<p>Number</p> <p>5-2. Alternate Accuracy and Frequency Re- sponse Check Setup 5-2</p> <p>5-3. Input Impedance Check Setup 5-4</p> <p>5-4. Location of Internal Adjustments 5-4</p> <p>6-1. Model 400GL Range Switch 6-2</p> <p>6-2. Model 400GL Component Location 6-3</p> <p>6-3. Model 400GL Schematic Diagram 6-3</p> <p>6-4. Preamplifier below Ser. No. 737-00456 . . 6-4</p> <p>7-1. Location of Important Mechanical Parts . 7-0</p>
--	--



Figure 1-1. Model 400GL AC Voltmeter

SECTION I

GENERAL INFORMATION

1-1. DESCRIPTION.

1-2. The -hp- Model 400GL is a versatile instrument designed for measuring ac voltages from $100\mu\text{V}$ to 1000 V rms, over a frequency range of from 20Hz to 4 MHz. The instrument has eight voltage ranges, divided in steps of 20 dB each, to correspond with the 20 dB logarithmic meter scale. A 100 kHz low pass filter is provided to reduce the effect of high frequency noise signals, when low frequency signals are being measured. The filter is effective on all voltage ranges, but is especially useful on the more sensitive ranges.

1-3. The Model 400GL may be used as a wideband ac amplifier, with a maximum open circuit gain of 80dB. The instrument has an ac output of 1 V rms (for full scale meter deflection) into an open circuit, or 0.5V rms into 600 ohms. The output is proportional to the meter indication on the voltage scale.

1-4. See Table 1-1 on next page for specifications.

1-5. ACCESSORIES.

1-6. Accessories available with the Model 400GL are the Model 11074A Voltage Divider Probe with Model 10111A banana post-to-BNC Adapter, and

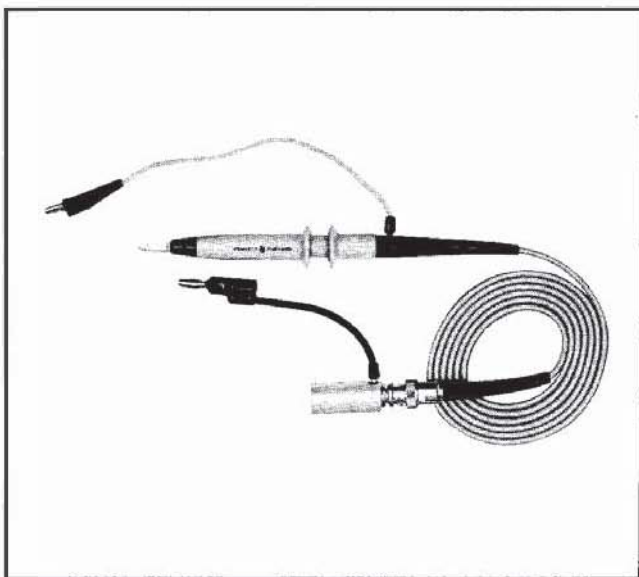

Figure 1-2. Model 11074A Voltage Divider Probe

Model 11076A Instrument Case. See Figures 1-2 and 1-3. The specifications for the Model 11074A are listed below:

Input Impedance: 10 megohms shunted by 10 pF
 Division Ratio: 10:1
 Division Accuracy: $\pm 2\%$
 Bandwidth: DC to 10 MHz
 Maximum Input Voltage: 1000 V rms

1-7. INSTRUMENT AND MANUAL IDENTIFICATION.

1-8. Hewlett-Packard instruments are identified by a two-section, eight-digit serial number (000-00000). If the first three digits of the serial number on your instrument do not agree with those on the title page of this manual, change sheets supplied with the manual will define differences between your instrument and the Model 400GL described in this manual.

1-9. If the first three digits of the two-section eight-digit serial number are prefixed with an E or G, your instrument was produced in Europe. An E000-00000 serial number indicates that the instrument was manufactured in England; a G000-00000 serial number indicates that the instrument was manufactured in Germany.

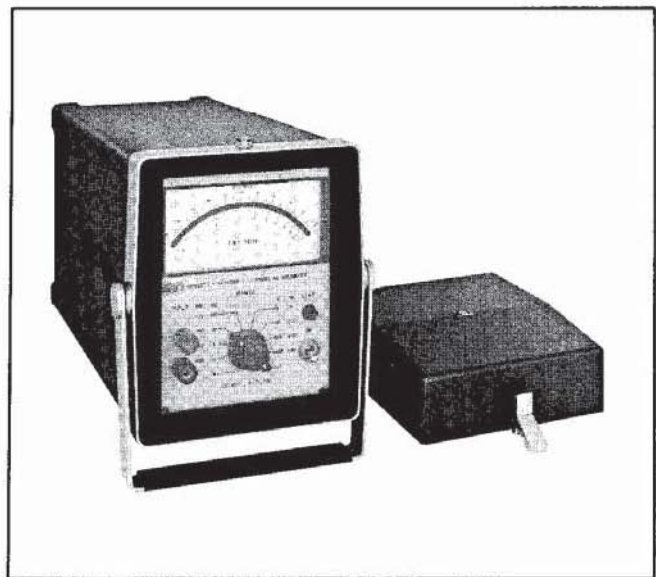

Figure 1-3. Model 11076A Instrument Case

Table 1-1. SPECIFICATIONS

ACCURACY (% of reading):

1 mV - 1000 V* ranges:

20 Hz	40 Hz	500 kHz	2 MHz	4 MHz
±0.4 dB	±0.2 dB	±0.4 dB	+0.2 dB	-0.8 dB

100 μV range:

30 Hz	60 Hz	100 kHz	500 kHz
±0.4 dB	±0.2 dB	+0.2 dB	-0.8 dB

* For input voltages greater than 300 volts, the high frequency range is limited to 100 kHz.

VOLTAGE RANGE: 100 μV to 1000 V full scale, eight ranges.

FREQUENCY RANGE: 20 Hz to 4 MHz.

CALIBRATION: Responds to average value of input waveform; calibrated in rms value of a sine wave. Linear dB scale, 100 divisions from -20 to 0 dB. Logarithmic voltage scale; 0 dB = 1 V.

NOISE REFERRED TO INPUT (1000 ohm termination):

Range	Filter In	Filter Out
1 mV - 1000 V	< 5 μV	< 30 μV
100 μV	< 5 μV	< 15 μV

Note: Noise adds to the signal approximately according to the relation:

$$\text{Reading} = \sqrt{(\text{signal})^2 + (\text{noise})^2}$$

RECOVERY FROM OVERLOAD: < 2 sec for 80 dB overload (1200 V max input).

INPUT IMPEDANCE:

Resistance: 10 MΩ, all ranges.

Capacitance: < 30 pF for 100 μV to 100 mV ranges. < 15 pF for 1 V to 1000 V ranges.

AMPLIFIER AC OUTPUT: 1 V rms open circuit (for full scale deflection), proportional to meter indication on voltage scale. Frequency response 20 Hz to 4 MHz on 1 mV to 1000 V range; 30 Hz to 100 kHz on 100 μV range. 100 kHz filter in the "in" position on 100 μV range.

AC POWER: 115 or 230 volts ±10%, 50 to 400 Hz, 5 watts.

EXTERNAL BATTERY OPERATION: Terminals are provided on rear panel; positive and negative voltages between 35 V and 55 V are required; current drain from each battery is approximately 45 mA. (External switching and on/off monitoring should be used for battery operation).

WEIGHT: Net 6 lbs (2.7 kg); shipping 8 lbs (3.6 kg).

OVERALL DIMENSIONS: 6 1/2" high; 5 1/8" wide; 11 11/16" deep.

SECTION II INSTALLATION

2-1. INTRODUCTION.

2-2. This section contains information and instructions necessary for the installation and shipping of the Model 400GL voltmeter. Included are initial inspection procedures, power and grounding requirements, installation information, and instructions for repackaging for shipment.

2-3. INITIAL INSPECTION.

2-4. This instrument was carefully inspected both mechanically and electrically before shipment. It should be physically free of marks or scratches and in perfect electrical order upon receipt. To confirm this, the instrument should be inspected for physical damage in transit. Also check for supplied accessories, and test the electrical performance of the instrument using the procedure outlined in Paragraph 5-5. If there is damage or deficiency, see the warranty on the inside front cover of this manual.

2-5. POWER REQUIREMENTS.

2-6. The Model 400GL can be operated from any source of 115 or 230 volts at 50 to 1000 cycles or from two 35 to 55 volt batteries connected to the rear panel BATTERY terminals. The 115/230 V slide switch on the rear panel selects the desired line voltage. Power dissipation is 5 watts maximum.

2-7. GROUNDING REQUIREMENTS.

2-8. To protect operating personnel, the National Electrical Manufacturers' Association (NEMA) recommends that the instrument panel and cabinet be grounded. All Hewlett-Packard instruments are equipped with a three-conductor power cable which, when plugged into an appropriate receptacle, grounds the instrument. The offset pin on the power cable three-prong connector is the ground wire.

2-9. To preserve the protection feature when operating the instrument from a two-contact outlet, use a three-prong to two-prong adapter and connect the green pigtail on the adapter to ground.

2-10. INSTALLATION.

2-11. The Model 400GL is fully transistorized; therefore, no special cooling is required. However, the instrument should not be operated where the ambient temperature exceeds 55° C (131°F) or the relative humidity exceeds 95%.

2-12. BENCH MOUNTING.

2-13. The Model 400GL is shipped with plastic feet and tilt stand in place, ready for use as a bench instrument.

2-14. RACK MOUNTING.

2-15. The Model 400GL may be rack mounted by using an adapter frame (-hp- Part No. 5060-0797). The

adapter frame is a rack frame that accepts any combination of submodular units. The adapter frame is used only for rack mounting. For additional information, address inquiries to your -hp- Sales and Service office. (See Appendix B for office location.)

2-16. COMBINATION MOUNTING.

2-17. The Model 400GL may be mounted in combination with other submodular units by using a Combining Case (-hp- Model 1051A or 1052A). The Combining Case is a full-module unit which accepts various combinations of submodular units. Being a full-module unit, it can be bench or rack mounted and is analogous to any full-module instrument.

2-18. REPACKAGING FOR SHIPMENT.

2-19. The following paragraphs contain a general guide for repackaging of the instrument for shipment. Refer to Paragraph 2-20 if the original container is to be used; 2-21 if it is not. If you have any questions, contact your local -hp- Sales and Service Office. (See Appendix B for office locations.)

NOTE

If the instrument is to be shipped to Hewlett-Packard for service or repair, attach a tag to the instrument identifying the owner and indicating the service or repair to be accomplished; include the model number and full serial number of the instrument. In any correspondence, identify the instrument by model number, serial number, and serial number prefix.

2-20. If original container is to be used, proceed as follows:

- a. Place instrument in container. If original container is not available, a suitable one can be purchased from your nearest -hp- Sales and Service Office.
- b. Ensure that container is well sealed with strong tape or metal bands.

2-21. If original container is not to be used, proceed as follows:

- a. Wrap instrument in heavy paper or plastic before placing in an inner container.
- b. Place packing material around all sides of instrument and protect panel face with cardboard strips.
- c. Place instrument and inner container in a heavy carton or wooden box and seal with strong tape or metal bands.
- d. Mark shipping container with "DELICATE INSTRUMENT", "FRAGILE" etc.

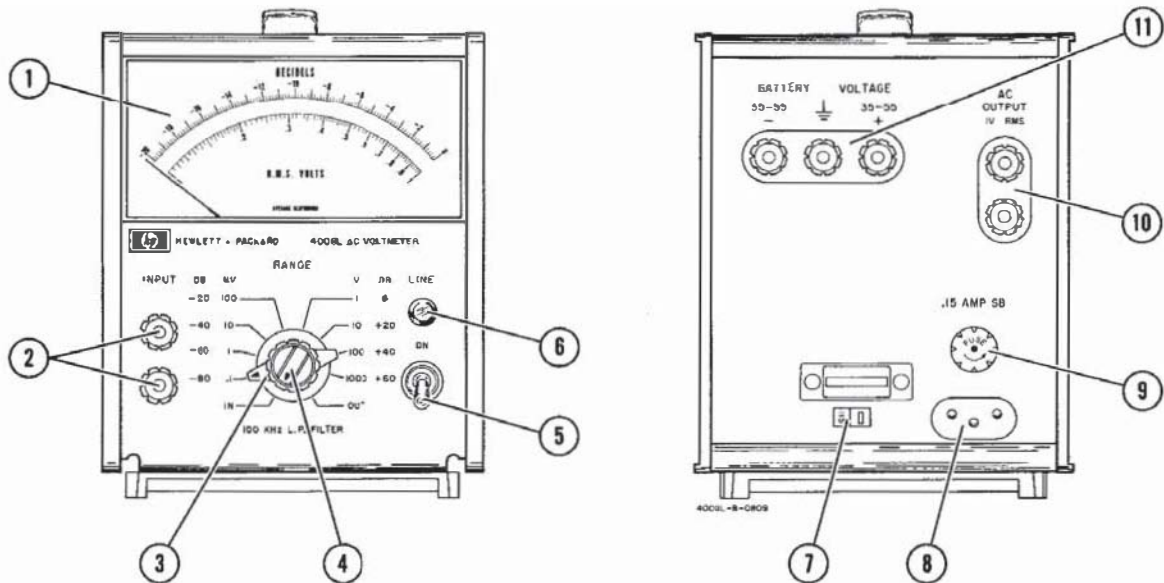

- ① **400GL Scale:** Indicates magnitude of applied signal in volts and dBm.
- ② **INPUT Terminals:** Connects signal to be measured to 400GL.
- ③ **RANGE Selector (S1):** Selects full scale reading of meter. Dbm reading on scale adds algebraically to dB setting of RANGE selector.
- ④ **100 KHz LP FILTER Switch (S2):** Switches 100 KHz filter either in or out of circuit.
- ⑤ **Line ON Toggle Switch (S3):** Applies primary power.
- ⑥ **LINE Indicator Lamp:** Indicates application of primary power.
- ⑦ **115/230 Volt Slide Switch (S4):** Sets 400GL to operate from either 115 V or 230 V, ac power source.
- ⑧ **Primary Power Connector:** Connects primary power to 400GL.
- ⑨ **FUSE:** Protects instrument against current overload.
- ⑩ **AC OUTPUT:** Ac amplifier output; output impedance is 600 Ω .
- ⑪ **BATTERY VOLTAGE Terminals:** 400GL may be powered by connecting two 35 to 55 volt batteries to these terminals.

Figure 3-1. Location of Controls and Indicators

SECTION III

OPERATING INSTRUCTIONS

3-1. INTRODUCTION.

3-2. This section contains instructions and information necessary for the operation of the 400GL AC Voltmeter. Included is identification of controls, indicators and connectors, turn on procedures, and operating instructions.

3-3. CONTROLS, INDICATORS AND CONNECTORS.

3-4. Each control, indicator, and connector on the 400GL is identified and described in Figure 3-1.

3-5. TURN ON PROCEDURES.

- a. If line voltage is used, ensure that the 115/230 Vac switch (located on the rear panel) is in the correct position. Set the line ON toggle switch to the ON position. The LINE lamp will glow, indicating that line power is applied.
- b. If batteries are used, connect two 35 to 55 volt batteries as shown in Figure 3-2. The line ON switch is not in the circuit when batteries are used, therefore an external DPST switch should be used to provide a means for disconnecting the batteries when the instrument is not in use.

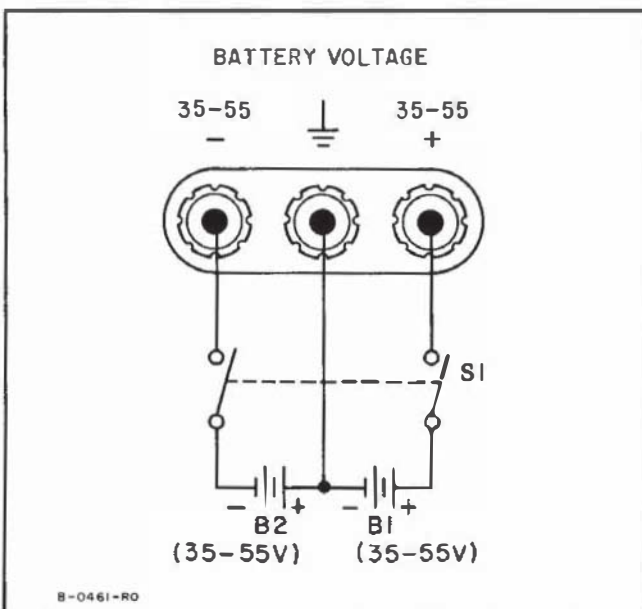

Figure 3-2. External Battery Connection

3-6. DB MEASUREMENTS.

- a. Perform the steps listed under Paragraph 3-5.
- b. Set the meter RANGE switch to the approximate range of the voltage to be measured.



DO NOT APPLY MORE THAN 1200 VOLTS TO INPUT. DO NOT OVERLOAD THE .1 MV THROUGH 100 MV RANGES WITH MORE THAN 300 VOLTS AT FREQUENCIES BELOW 300 KHz OR WITH MORE THAN 64 VOLTS AT FREQUENCIES ABOVE 300 KHz. IF ANY OF THESE OVERLOADS ARE EXCEEDED, THE INSTRUMENT MAY BE DAMAGED.

- c. If the signal to be measured is a frequency less than 100 kHz, the 100 KHz LP FILTER may be switched in to filter out all frequency components above 100 kHz.
- d. Connect the signal to be measured to the INPUT terminals.
- e. The dB measurement is equal to the algebraic sum of the meter indication and the RANGE setting. For example: if the RANGE setting is +20dB, and the meter reading is -3dB, the actual dB measurement is +17dB.

3-7. AC VOLTAGE MEASUREMENTS.

NOTE

Since the 400GL is average responding and rms calibrated, any distortion will affect the accuracy of the measurement. Table 3-1 shows the errors caused by distortions.

Table 3-1

Effect of Distortion on Average Responding Meter

HARMONIC	%DISTORTION	% ERROR (* Fundamental)	
		MAX. POSITIVE	MAX. NEGATIVE
Any even	0.1	0.000	
	0.5	0.001	
	1.0	0.005	
	2.0	0.020	
Third	0.1	0.003	0.033
	0.5	0.168	0.167
	1.0	0.338	0.328
	2.0	0.687	0.667
Fifth	0.1	0.020	0.020
	0.5	0.101	0.099
	1.0	0.205	0.195
	2.0	0.420	0.380

*Depends on phase relationship between harmonic and fundamental.

- a. Perform steps a through d of Paragraph 3-6.
- b. The meter will indicate the rms voltage amplitude of the sinusoidal input signal.

3-8. WIDE BAND AC AMPLIFIER.



EXTREME CARE SHOULD BE TAKEN
TO AVOID COMMON GROUND PATHS

BETWEEN THE INPUT AND OUTPUT SIGNALS. BECAUSE OF THE HIGH GAIN OF THE INSTRUMENT ON THE MORE SENSITIVE RANGES (80 DB ON .1 MV RANGE, ETC.), COMMON GROUND PATHS CAN CAUSE OSCILLATIONS AT HIGHER FREQUENCIES.

- a. Perform the steps listed in Paragraph 3-5.
- b. Set the meter RANGE switch to the approximate range of the input signal.
- c. When signals of frequencies less than 100 kHz are being amplified, the 100 KHz L. P. FILTER may be switched in to reduce high frequency noise and lessen the possibility of oscillations.
- d. Connect the input signal to the INPUT terminals, and connect the load to the AC OUTPUT terminals.
- e. Table 3-2 shows the gain factor for each range of the 400GL, into an open circuit.

Table 3-2. AC Amplifier Gain Factors

RANGE	GAIN	RANGE	GAIN
1000 V	-60dB	100 mV	+20dB
100 V	-40dB	10 mV	+40dB
10 V	-20dB	1 mV	+60dB
1 V	0dB	.1 mV	+80dB

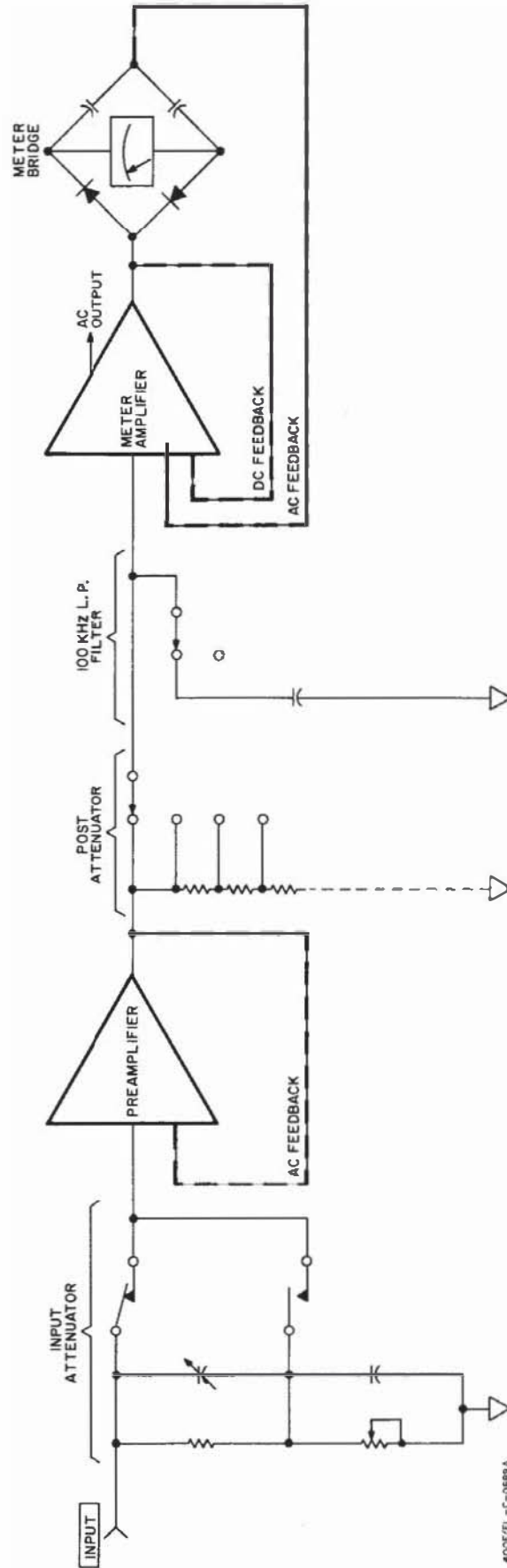

Figure 4-1. Functional Circuit Diagram

SECTION IV

THEORY OF OPERATION

4-1. GENERAL.

4-2. The 400GL is a solid state, average responding, rms calibrated ac voltmeter. It may also be used as a wide band ac amplifier, with switchable gain and switchable bandwidth. Refer to Figure 4-1 for a functional circuit diagram of the instrument.

4-3. BLOCK DIAGRAM DESCRIPTION.

4-4. The voltage to be measured is applied to the input attenuator, where it is either attenuated by 60 dB, or coupled directly to the preamplifier. The preamplifier provides 10dB of gain for the input signal and applies it to the post attenuator. The signal goes from the post attenuator to the 100 KHz Low Pass filter, which may be switched in to limit the bandwidth to signals from 20Hz to 100 kHz. The meter amplifier then amplifies the signal, couples it to the meter bridge, and supplies a signal to the AC OUTPUT terminal. The meter bridge rectifies the ac signal and applies it to meter M1, which indicates the rms value of the input voltage. The meter bridge also provides the ac feedback to the meter amplifier.

4-5. SCHEMATIC THEORY.

4-6. Refer to Figure 6-3 for the following discussion.

4-7. INPUT ATTENUATOR.

4-8. The input attenuator consists of an rc voltage divider and two reed relays. On the .1 mV through 100 mV ranges, reed relay A1K1 is energized by -26 V from wafer (A) of the RANGE switch, S1, routing the input signal directly to the preamplifier. On all other ranges, the -26 V is applied to relay A1K2. When A1K2 is closed, the input signal is attenuated 60dB by the rc divider and coupled to the preamplifier.

4-9. PREAMPLIFIER.

4-10. The preamplifier is a three stage ac amplifier that amplifies the signal from the input attenuator by 10dB. It also functions as an impedance matcher to match the high impedance of the input attenuator to the much lower impedance of the post attenuator.

4-11. Capacitor A2C5 blocks dc transients and couples the ac signal to the preamplifier. The input signal is limited to 5.4 volts peak-to-peak by diodes A2CR2 and A2CR4, which are biased at +2.7 V and -2.7 V respectively, by zener diodes A2CR1 and A2CR5. A field effect transistor, A2Q1, is used as the input stage of the preamplifier because of its low noise characteristics and high input impedance. The signal is taken from the drain of A2Q1 and is further amplified by A2Q2 and A2Q3.

4-12. Feedback from the emitter of A2Q2 bootstraps the value of A2R9, the drain load of A2Q1. Feedback from the source of A2Q1 bootstraps the input impedance of the preamplifier and keeps it at a high level

over all ranges of inputs. Gain stability and linearity of the preamplifier are maintained by feedback from the emitter of A2Q3. A2R6 provides a bias adjustment for the field effect transistor, A2Q1.

4-13. POST ATTENUATOR.

4-14. The post attenuator is a precision resistive voltage divider that operates as a function of the RANGE switch. On the lowest voltage range, the signal from the preamplifier is applied through two resistors (S1R1 and S1R17) to the 100 KHz LP FILTER, and receives no attenuation. A precision resistive divider circuit provides signal attenuation in progressive steps of 20dB for the seven higher ranges.

4-15. 100 KHz LOW PASS FILTER.

4-16. The 100 KHz LP FILTER is a 0.01 μ F capacitor (S2C1) which may be switched into or out of the circuit by switch S2. When the filter is in the circuit, the bandwidth of the instrument is from 20 Hz to 100 kHz. If the filter is switched out of the circuit, the bandwidth is increased to 4 MHz. Refer to Figure 4-2 for a graph of the filter attenuation characteristics.

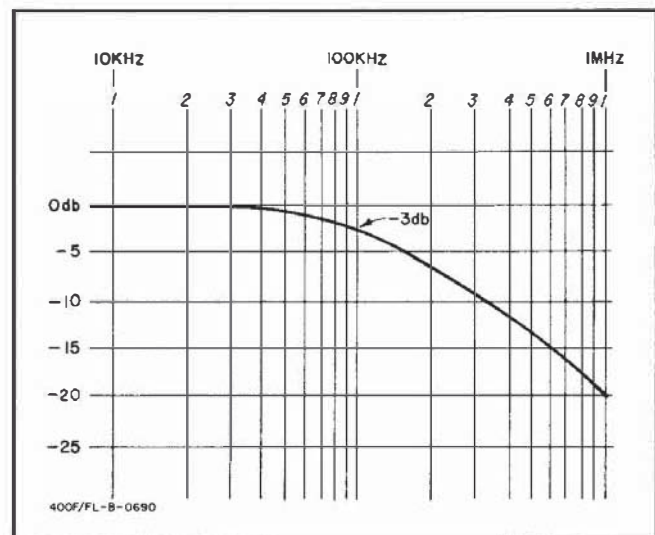

Figure 4-2. Filter Attenuation Characteristics

4-17. METER AMPLIFIER.

4-18. The meter amplifier is a four stage, direct coupled voltage and power amplifier. The first stage is a differential amplifier, A2Q10 and A2Q12, which amplifies the difference between the input signal and the feedback signal on the base of A2Q12. The three other stages of amplification are provided by A2Q11, A2Q13, and A2Q15.

4-19. The ac feedback from the meter bridge is adjustable at 4 MHz (A2C36) and 400 Hz (A2R62) on the -40dB range. On the -80dB range, A2R64, A2R67, and A2R68 are switched into the circuit to increase

the gain of the amplifier by 10dB and to allow a 400 Hz gain adjustment to be made.

4-20. The dc feedback from the collector of A2Q15 is adjustable at 20 Hz (A2R59) on the -40dB range. A2R58 is switched into the circuit on the -80dB range to provide a feedback adjustment at 30 Hz. These adjustments provide overall amplifier gain stability for the entire voltage and frequency range of the instrument.

4-21. A2Q14 isolates the AC OUTPUT circuit from the meter amplifier and the meter bridge. It is an independent current source which will supply a signal to the OUTPUT terminal that is identical to the signal applied to the meter bridge. That is, for a 1 V rms signal for full scale meter deflection, A2Q14 will provide a 1 V rms signal at the AC OUTPUT terminal, into an open circuit.

4-22. METER BRIDGE.

4-23. Refer to Figure 4-3 for a simplified diagram of the metering circuit.

4-24. The meter bridge is a full wave rectifier that converts the ac signal from the meter amplifier into dc. It supplies current to drive the meter and provides an ac feedback signal to the meter amplifier.

4-25. Transistor A2Q16 provides a large output impedance for the meter amplifier, and is the current drive source for the meter bridge circuit. The collector output of A2Q16 is applied to the meter bridge,

and is rectified by diodes A2CR22 and A2CR23. The ac components of the bridge signal are coupled into the feedback loop by capacitors A2C38 and A2C39. Transistor A2Q17 bootstraps the resistance of A2R69 to a high value, so that current is driven through the bridge, keeping the meter circuit response linear to large variations in signal amplitude.

4-26. The meter, M1, is a current driven device that utilizes a taut-band movement. It responds to the average value of the rectified meter amplifier output, which is proportional to the rms value of the sinusoidal signal being measured. The meter indicates the rms value of the input signal in volts and dB. The meter scale is calibrated so that 0dB corresponds to 1 volt. The meter is protected from circuit transients and overloads by capacitor C1.

4-27. POWER SUPPLY.

4-28. The power supply provides both a positive and negative 26 V regulated output. It may be operated by external batteries (+35 V to 55 V and -35 V to 55V) or line power (115 V or 230 V, 50 Hz to 1000 Hz).

4-29. The line input is converted to dc by a diode rectifier network consisting of A2CR6 through A2CR9. The positive output of the rectifier is applied to series regulator A2Q4, which regulates the +26 V supply. Control transistor A2Q6 has a constant emitter reference voltage supplied by zener diode A2CR13. Capacitor A2C16 couples any change in the +26 V output

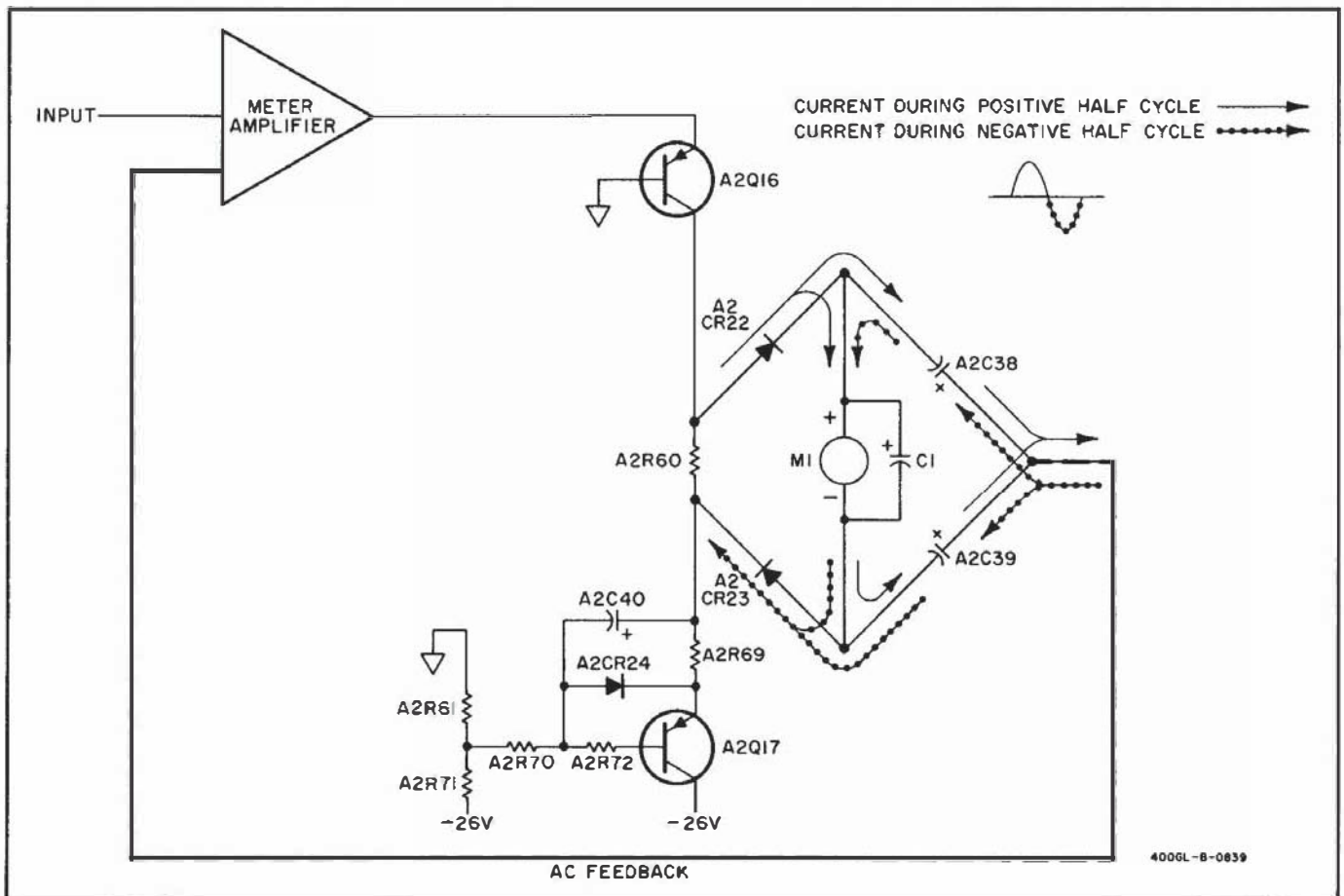

Figure 4-3. Simplified Diagram of Metering Circuit

to the base of A2Q6, which will supply a signal proportional to the change in output voltage to A2Q5. A2Q5 will then amplify the signal and couple it to the base of the regulator A2Q4, causing it to regulate the output by either increasing or decreasing conduction.

4-30. The -26 V supply is regulated in the same manner, the only difference being that the control transistor A2Q7 is referenced to the +26 V output, instead of the zener diode.

Table 5-1. Test Equipment

INSTRUMENT TYPE	REQUIRED CHARACTERISTICS	USE	RECOMMENDED MODEL
AC Voltmeter Calibrator	Accuracy: 0.2% at 400 Hz Range: 5 mV to 1 V	Performance Checks and Calibration	-hp- Model 738BR Voltmeter Calibrator
Test Oscillator	Output: 5 mV to 1 V Frequency Range: 20 Hz to 4 MHz Distortion: < 1% Flatness: $\pm 0.25\%$	Performance Checks and Calibration	-hp- Model 652A Test Oscillator or Combination -hp- Model 739AR Frequency Response Test Set and -hp- Model 200SR Oscillator
AC/DC Voltmeter/Ohmmeter	Volts Accuracy: 2% Ohms Accuracy: 5%	Troubleshooting	-hp- Model 427A Voltmeter
Resistor	Fxd, 100 K Ω $\pm 1\%$	Performance Checks	-hp- Part No. 0757-0465
Resistor	Fxd, 200 K Ω $\pm 1\%$	Performance Checks	-hp- Part No. 0757-0128
Terminating Resistance	Feed-through, 50 Ω impedance	Performance Checks and Calibration	-hp- Part No. 11048B Feed-through Termination
Crystal Socket (with Terminals shorted)	Size: 1/2 inch	Performance Checks and Calibration (Shorting Test Points)	-hp- Part No. 1200-0028

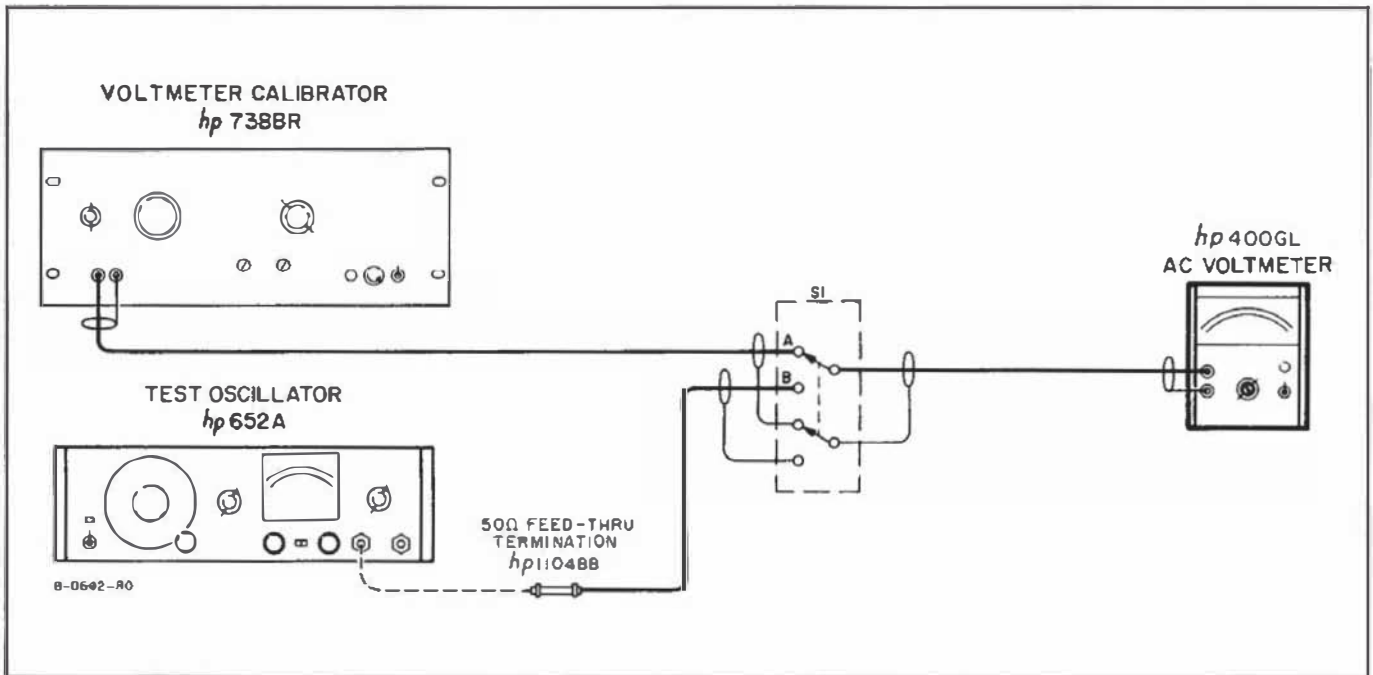

Figure 5-1. Accuracy and Frequency Response Check Setup

SECTION V MAINTENANCE

5-1. INTRODUCTION.

5-2. This section contains maintenance and service information for the Model 400GL AC Voltmeter. Included are Performance Checks, Alignment and Calibration Procedures, and Troubleshooting Procedures.

5-3. TEST EQUIPMENT REQUIRED.

5-4. The equipment required to properly maintain the 400GL is listed in Table 5-1. The table lists the type of equipment to be used, the specification requirements, and the recommended commercially available test equipment.

5-5. PERFORMANCE CHECKS.

5-6. The following Performance Checks compare the 400GL with its accuracy specifications (Table 1-1). These checks may be used for incoming inspection, periodic maintenance, and for specification checks after a repair. A highly accurate and stable voltage reference that is variable from 20 Hz to 4 MHz is required for the performance checks. The -hp- 738BR Voltmeter Calibrator produces a 400 Hz signal that is within less than 0.2% of the indicated output. The -hp- 652A Test Oscillator can be referenced to the output of the 738BR and can be adjusted to within 0.25% of the set reference voltage from 20 Hz to 4 MHz.

5-7. If the -hp- 652A Test Oscillator is not available, the -hp- 739AR Frequency Response Test Set and 200SR Oscillator combination may be used. This combination can be adjusted to within 0.5% of a set voltage reference from 20 Hz to 4 MHz. (The -hp- 739AR, -hp- 200SR, and -hp- 738BR are available in a rack mounted configuration designated -hp- K02-738BR VTVM Calibration System.)

5-8. The following procedures specify the use of the -hp- 652A and the -hp- 738BR. If the K02-738BR calibration system is used, follow the same general procedures.

5-9. Figure 5-1 shows the test setup for using the -hp- 652A and -hp- 738BR combination. Figure 5-2 shows the test setup for using the K02-738BR VTVM Calibration System.

NOTE

The -80dB (0.1 mV) range of the 400GL may be checked for accuracy by verification of the additional 10dB of gain that is provided by the meter amplifier on that range. In order to verify the gain, the top cover of the instrument must be removed to gain access to TP1 through TP4.

5-10. TOP COVER REMOVAL

5-11. To remove or replace the top cover, follow the procedures outlined in Paragraph 5-25.

5-12. ACCURACY AND FREQUENCY RESPONSE CHECKS.

5-13. The accuracy and frequency response checks compare the 400GL with its accuracy specifications over the entire frequency range of the instrument.

5-14. Connect the voltmeter calibrator and the test oscillator to the 400GL as shown in Figure 5-1. An external switch (S1) should be used to facilitate switching from one test instrument to the other.

5-15. -40dB RANGE.

- a. Set 400GL RANGE switch to -40dB (10mV) and set 100 KHz L. P. FILTER switch to OUT.
- b. Set switch S1 to position A.
- c. Adjust voltmeter calibrator for a 5 mV rms output, at 400 Hz.
- d. Note 400GL meter indication. If meter indication is not within tolerances listed in Table 5-2, perform the meter calibration (Paragraph 5-30).
- e. Set switch S1 to position B. Set test oscillator to 400 Hz, and adjust amplitude controls until 400GL meter indication is the same as in step d of this paragraph. Set a reference on meter of test oscillator, and use amplitude controls to maintain the set reference whenever frequency of oscillator is varied.
- f. Repeat step d of this paragraph for each frequency listed in Table 5-2.

5-16. -20dB RANGE (-80dB RANGE CHECK.)

- a. Set 400GL RANGE switch to -20dB (100mV), and set 100 KHz L. P. FILTER switch to OUT.
- b. Set switch S1 to position A.
- c. Adjust voltmeter calibrator for a 10 mV rms output, at 400 Hz.
- d. Short TP1 to TP4, and short TP2 to TP3. (A shorting device, such as a crystal socket with its terminals shorted together, should be used to avoid pickup of noise.) The meter should indicate -10dB \pm 0.2dB, verifying the additional 10dB of gain that is provided by the meter amplifier on the -80dB range (0.1 mV). Note meter indication.
- e. Set switch S1 to position B.

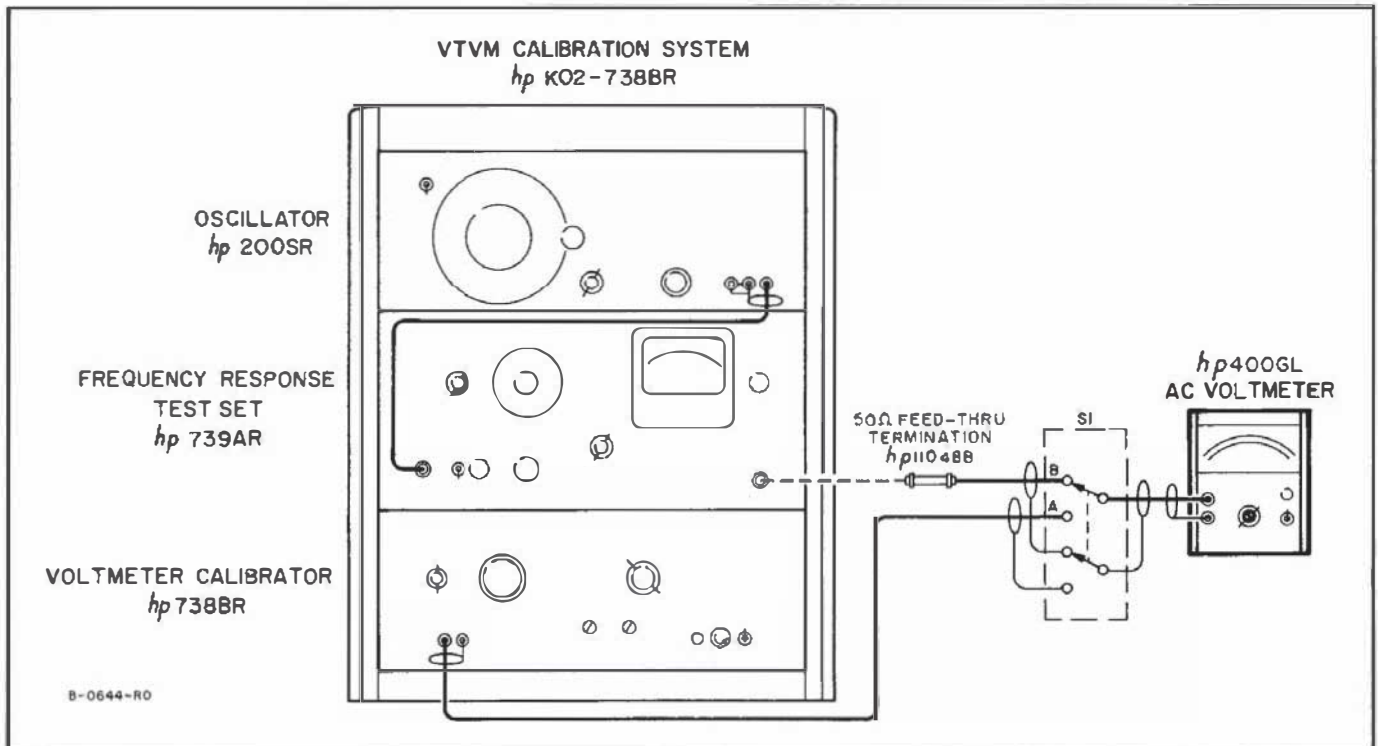

Figure 5-2. Alternate Accuracy and Frequency Response Check Setup

- f. Set test oscillator to 400 Hz, and adjust amplitude controls until 400GL indication is same as in step d of this paragraph. Set a reference on meter of test oscillator, and use amplitude controls to maintain set reference whenever frequency of oscillator is changed.
- g. Set test oscillator to each frequency listed in Table 5-2, and observe the 400GL meter indication for each different frequency. If each meter indication is not within the tolerances listed in Table 5-2, perform the Meter Calibration (Paragraph 5-30).
- h. Remove shorting device from test points.

5-17. 0dB RANGE.

- a. Set 400GL RANGE switch to 0dB (1V), and set 100 KHz L. P. FILTER switch to OUT.
- b. Set switch S1 to position A.
- c. Adjust voltmeter calibrator for a 0.5 V rms output at 400 Hz.
- d. Note 400GL meter indication. If meter indication is not within tolerances listed in Table 5-2, perform the meter calibration (Paragraph 5-30).
- e. Set switch S1 to position B. Set test oscillator to 400 Hz, and adjust amplitude controls until 400GL meter indication is same as in step d of this paragraph. Set a reference on meter of test oscillator, and use amplitude controls to maintain set reference, whenever frequency of oscillator is changed.
- f. Repeat step d of this paragraph for each fre-

quency listed in Table 5-2.

5-18. RANGE TRACKING CHECK.

5-19. The following procedures are used to verify the tracking accuracy of the 400GL on two voltage ranges, over the entire frequency range of the instrument. Use the test setup shown in Figure 5-1 for the range tracking check.

- a. Set 400GL RANGE switch to -20dB (100mV), and set 100 KHz L. P. FILTER switch to OUT.
- b. Set switch S1 to position A.
- c. Adjust voltmeter calibrator for a 30 mV rms output, at 400 Hz.
- d. Note 400GL meter indication. If meter indication is not within tolerances listed in Table 5-3, perform the meter calibration (Paragraph 5-30).
- e. Set switch S1 to position B. Set test oscillator to 400 Hz, and adjust amplitude controls until 400GL meter indication is same as in step d of this paragraph. Set a reference on meter of test oscillator, and use amplitude controls to maintain the set reference whenever frequency of oscillator is varied.
- f. Repeat step d of this paragraph for each frequency listed in Table 5-3.
- g. Set switch S1 to position A.
- h. Adjust voltmeter calibrator for a 15 mV rms output at 400 Hz.
- i. Repeat steps d, e, and f of this paragraph.
- j. Set 400GL RANGE switch to 0dB (1 V).

Table 5-2. Meter Calibration Tolerances

-40 dB RANGE			-20 dB RANGE (-80dB Range Check)			0dB RANGE		
FREQ.	METER INDICATION(dB)		FREQ.	METER INDICATION(dB)		FREQ.	METER INDICATION(dB)	
	MIN.	MAX.		MIN.	MAX.		MIN.	MAX.
20	-6.4	-5.6	30	-10.4	-9.6	20	-6.4	-5.6
40	-6.4	-5.6	60	-10.4	-9.6	40	-6.4	-5.6
400	-6.2	-5.8	400	-10.2	-9.6	400	-6.2	-5.8
1000	-6.2	-5.8	1000	-10.2	-9.8	1000	-6.2	-5.8
10 K	-6.2	-5.8	10 K	-10.2	-9.8	10 K	-6.2	-5.8
100 K	-6.2	-5.8	100 K	-10.2	-9.8	100 K	-6.2	-5.8
1 M	-6.4	-5.6	300 K	-10.8	-9.8	1 M	-6.4	-5.6
2 M	-6.4	-5.6	500 K	-10.8	-9.8	2 M	-6.4	-5.6
4 M	-6.8	-5.8				4 M	-6.6	-5.8

Table 5-3. Range Tracking Tolerances

FREQ.	-20 dB RANGE				0dB RANGE			
	30 mV INPUT METER INDICATION(dB)		15 mV INPUT METER INDICATION(dB)		0.3 V INPUT METER INDICATION(dB)		0.15 V INPUT METER INDICATION(dB)	
	MIN.	MAX.	MIN.	MAX.	MIN.	MAX.	MIN.	MAX.
20	-10.9	-10.1	-16.9	-16.1	-10.9	-10.1	-16.9	-16.1
40	-10.9	-10.1	-16.9	-16.1	-10.9	-10.1	-16.9	-16.1
400	-10.7	-10.3	-16.7	-16.3	-10.7	-10.3	-16.7	-16.3
1000	-10.7	-10.3	-16.7	-16.3	-10.7	-10.3	-16.7	-16.3
1 K	-10.7	-10.3	-16.7	-16.3	-10.7	-10.3	-16.7	-16.3
100 K	-10.7	-10.3	-16.7	-16.3	-10.7	-10.3	-16.7	-16.3
1 M	-10.9	-10.1	-16.9	-16.1	-10.9	-10.1	-16.9	-16.1
2 M	-10.9	-10.1	-16.9	-16.1	-10.9	-10.1	-16.9	-16.1
4 M	-11.3	-10.3	-17.3	-16.3	-11.3	-10.3	-17.3	-16.3

- k. Set switch S1 to position A.
- l. Adjust voltmeter calibrator for a 0.3 V rms output at 400 Hz.
- m. Repeat steps d, e, and f of this paragraph.
- n. Set switch S1 to position A.
- o. Adjust voltmeter calibrator for a 0.15 V rms output at 400 Hz.
- p. Repeat steps d, e, and f of this paragraph.

5-20. INPUT IMPEDANCE CHECK.

5-21. INPUT RESISTANCE CHECK.

- a. Connect 50 Ω output of test oscillator to 400GL.
- b. Set 400GL RANGE switch to 0dB(1V), and set 100KHz L. P. FILTER switch to OUT.
- c. Set test oscillator output for full scale meter

deflection of 400GL at 400 Hz.

- d. Connect resistor R1 between test oscillator and 400GL as shown in Figure 5-3. (R1 = 200 KΩ).
- e. 400GL meter indication should not drop more than 0.2 dB from full scale. This verifies an input resistance of 10 MΩ.

5-22. INPUT CAPACITY CHECK.

- a. Connect test oscillator and resistor R1 to 400GL as shown in Figure 5-3. (R1 = 100 KΩ). Connect resistor lead directly to GR connector.
- b. Set 400GL RANGE switch to 0dB (1V), and set 100 KHz L. P. FILTER switch to OUT.
- c. Set test oscillator output for full scale deflection of 400GL meter at 400 Hz.
- d. Increase frequency of test oscillator until 400GL indication drops to -3dB. This should

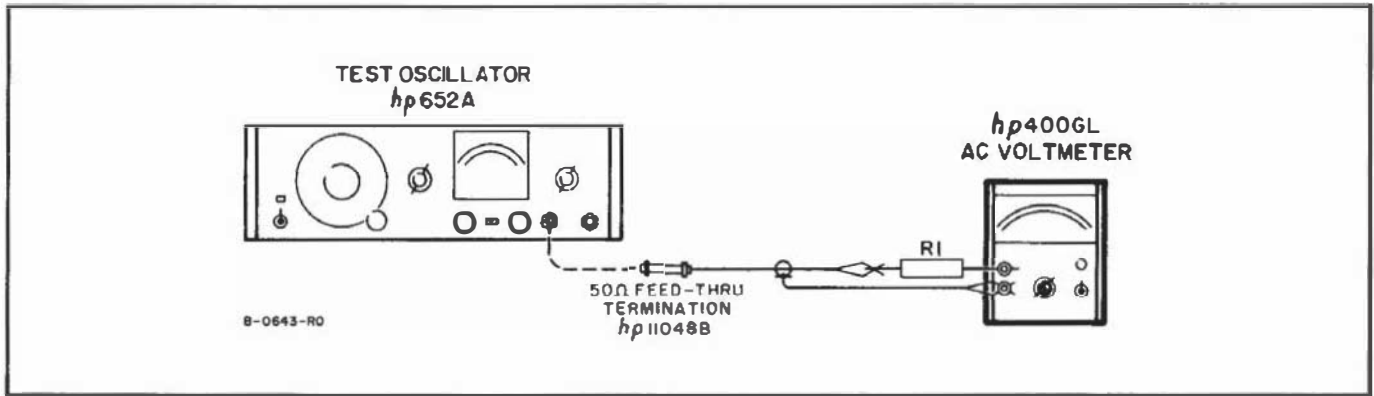

Figure 5-3. Input Impedance Check Setup

occur at a frequency of 106 kHz or greater, verifying an input capacity of 15 pF or less on the 0dB range.

- e. Set 400GL RANGE switch to -20 dB(100 mV).
- f. Set frequency response test set output for full scale deflection of 400GL meter at 400 Hz.
- g. Increase frequency of test oscillator until 400 GL indication drops to -3 dB. This should occur at a frequency of 53 kHz or greater, verifying an input capacity of 30 pF or less on the -20 dB range.

5-23. ALIGNMENT AND CALIBRATION PROCEDURES.

5-24. The alignment and Calibration Procedures should be performed only if it has been determined by the Performance Checks that the 400GL is not within specifications. The following procedures

specify the use of an -hp- 738BR Voltmeter Calibrator and an -hp- 652A Test Oscillator. However, an -hp- K02-738BR VTVM Calibration System may be substituted if the same general procedures are followed. If the instrument cannot be properly adjusted, refer to Paragraph 5-41, Troubleshooting Procedures. Refer to Figure 5-4 for the location of internal adjustments.

5-25. COVER REMOVAL AND REPLACEMENT.

5-26. Removal of the top cover exposes circuit areas for routine checks and adjustments. Removal of the bottom and side covers exposes circuit areas for operations such as soldering and component replacement.

5-27. TOP OR BOTTOM COVERS.

- a. Remove screw at rear of cover; also remove two screws on side of top cover. Slide cover about 1 inch to rear, and lift it off.

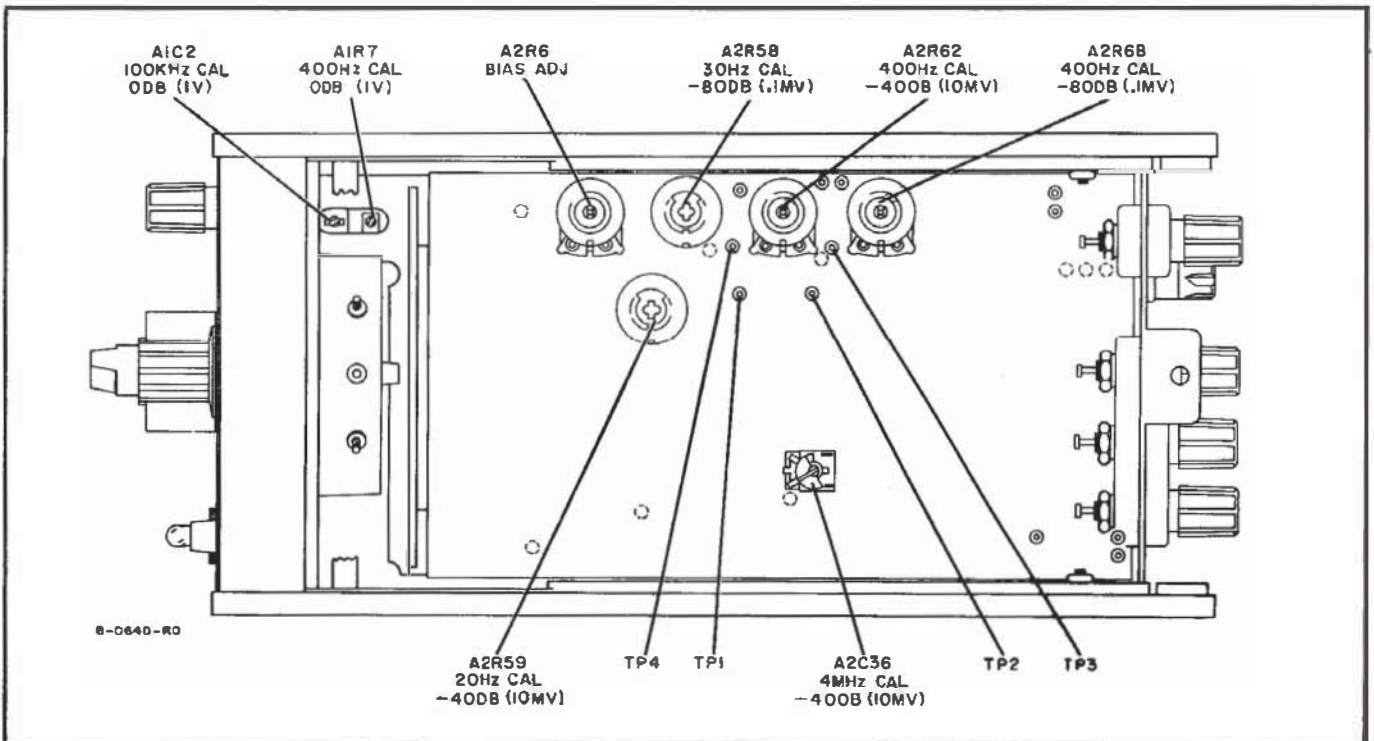

Figure 5-4. Location of Internal Adjustments

- b. To replace cover reverse the removal procedure.

5-28. SIDE COVER.

- 5-29. Remove the four screws from side cover, and lift it off.

5-30. METER CALIBRATION.

5-31. The following procedures are used to adjust the gain of the meter amplifier on two voltage ranges at five different frequencies. Proper gain adjustments will assure accurate meter indications over the entire voltage and frequency range of the instrument. Use the test setup shown in Figure 5-1 for the meter calibration.

5-32. Meter Calibration, -40dB RANGE.

- a. Set switch S1 to Position A.
- b. Set 400GL RANGE switch to -40 dB (10 mV), and set 100 KHz L. P. FILTER switch to OUT.
- c. Set voltmeter calibrator for 10 mV output at 400 Hz.
- d. Adjust A2R62 for a 400GL full scale meter indication.
- e. Set switch S1 to Position B.
- f. Adjust test oscillator for a 400GL full scale meter indication at 400 Hz. Set a reference on meter of test oscillator and use amplitude controls to maintain reference whenever frequency of oscillator is changed.
- g. Set test oscillator to 20 Hz.
- h. Adjust A2R59 for a 400GL full scale meter indication.
- i. Set test oscillator to 4 MHz.
- j. Adjust A2C36 for a 400GL full scale meter indication.

5-33. METER CALIBRATION, -80dB RANGE.

NOTE

The -80dB range meter calibration is performed on a higher range. This is done by shorting test points which provide the amplifier with the additional 10dB of gain that normally is switched in only on the -80dB range.

- a. Set switch S1 to Position B.
- b. Set 400GL RANGE switch to -40dB (10 mV) and set 100 KHz L. P. FILTER switch to OUT.
- c. Set test oscillator to 400 Hz, and adjust for a 400GL meter indication of -10dB.
- d. Short TP1 to TP4 and short TP2 to TP3. (This increases the gain of the meter amplifier by 10dB, as if the instrument were on the -80dB range.)
- e. Adjust A2R68 for a 400GL full scale meter indication. Remove shorting device from test points.

- f. Set test oscillator to 30 Hz, and adjust for a 400GL meter indication of -10dB.
- g. Short TP1 to TP4 and short TP2 to TP3.
- h. Adjust A2R58 for a 400GL full scale meter indication.

5-34. ATTENUATOR ALIGNMENT.

5-35. The following procedures are used to properly align the input attenuator of the 400GL at both high and low frequencies. Use the test setup shown in Figure 5-1 for the attenuator alignment.

- a. Set switch S1 to Position A.
- b. Set 400GL RANGE switch to 0dB (1V), and set 100 KHz L. P. FILTER switch to OUT.
- c. Adjust voltmeter calibrator for a 1 volt output at 400 Hz.
- d. Adjust A1R7 for a 400GL full scale meter indication.
- e. Set switch S1 to position B.
- f. Set test oscillator for a 400GL full scale meter indication, at 400 Hz.
- g. Set test oscillator to 100 kHz, maintaining a constant amplitude.
- h. Adjust A1C2 for a 400GL full scale meter indication. If more than a 0.2 dB adjustment is needed, repeat the 400 Hz adjustment.

5-36. A2Q1 BIAS ADJUSTMENT.

5-37. A2R6 provides a bias adjustment for field effect transistor A2Q1.

- a. Monitor voltage at junction between A2R5 and A2R3 with a dc voltmeter.
- b. Adjust A2R6 for a +6 V (-6 V for Ser. No. below 737-00456) indication at the junction.

5-38. REPLACEMENT OF A2C37*.

5-39. The value of A2C37 is individually selected to compensate for varying circuit parameters within the instrument. Certain Model 400GL instruments may not have a capacitor in this location.

5-40. If an instrument cannot be properly calibrated on the -40dB range at 4 MHz, A2C37 should be changed. Increase the value of A2C37 if the instrument meter indication is high and cannot be adjusted low enough; decrease the value of A2C37 if the instrument meter indication is low and cannot be adjusted high enough.

5-41. TROUBLESHOOTING PROCEDURE.

5-42. If the 400GL is operating improperly, it either needs to be calibrated or has a circuit that is malfunctioning. Troubleshoot the instrument only after it has been determined that the malfunction cannot be corrected by performing the Alignment and Calibration Procedures in Paragraph 5-23.

Table 5-4 Troubleshooting Guide

MALFUNCTION INDICATION	PROBABLE TROUBLE
Instrument will not operate on line voltage, and LINE ON lamp will not light.	Fuse F1 open.
Instrument will not uprange above -20dB (100mV), but works on -20dB range and below.	Relay A2K1 stuck closed, or A2K2 stuck open.
Instrument will not downrange below 0dB(1V), but works on 0dB range and above.	Relay A2K1 stuck open, or A2K2 stuck closed.
Voltage at A2R8 cannot be properly adjusted.	Impedance Converter Circuit (A2Q1, A2Q2 and A2Q3).
No voltage at A2L1.	Jumper wire #1 broken.
Power supply output unregulated.	A2Q6, A2Q7 or Zener diode A2CR13.
No ac output.	A2R33 shorted, or A2C26 open.
Instrument operates improperly with inputs above 100 kHz, but works with inputs of lower frequencies.	Filter switch S2.
Instrument will not operate properly on -80dB range (0.1 mV).	Range switch S1, wafer D.
Meter deflection on all ranges with no input.	A2Q15, A2Q16, A2Q17. A2C38, A2C39 or A2C40.
Meter remains at zero with any input on any range.	Capacitor C1 shorted.

5-43. When a malfunction occurs, remove power from the 400GL and visually inspect for loose or broken wires and connectors. Also check for overheated or loose components and similar conditions that could be a source of trouble.

5-44. The checks outlined in this section were not designed to measure all circuit parameters, but to localize the malfunction. Therefore, it is probable that additional checks and measurements will be required to completely isolate the faulty component.

5-45. Refer to Table 5-4 for a list of possible malfunctions and their probable causes.

NOTE

All the voltage measurements in this section should be made with the 400GL input shorted and the RANGE switch set to 0dB (1V).

5-46. POWER SUPPLY.

5-47. Measure the power supply outputs at jumper wires #1 and #2 for +26 V and -26 V respectively. If both outputs are incorrect, first check the components in the +26 V section of the power supply, because the control transistor in the -26 V supply is referenced to the +26 V output. Consequently, if the +26 V becomes unregulated, the -26 V will also be unregulated. Refer to Table 5-5 for a list of check point voltages in the power supply.

Table 5-5. Power Supply Voltages

CHECK POINT	VOLTAGE
Emitter Q4	+26.0 V ±1 V
Collector Q4	+41.5 V ±5 V
Collector Q6	+27.5 V ±1 V
Emitter Q8	-26.0 V ±1 V
Emitter Q9	-43.5 V ±5 V

5-48. AMPLIFIERS.

5-49. Both the preamplifier and the meter amplifier are internally dc coupled. If the dc voltages anywhere in the amplifiers are incorrect, the amplifiers will not operate properly. Measure the dc voltages in the amplifiers at the check points listed in Tables 5-6 and 5-7.

Table 5-6. Preamplifier Voltages

CHECK POINT	VOLTAGE
Source Q1	+2.3 V ±0.5 V
Drain Q1	+17.0 V ±2.0 V
Collector Q2	+7.5 V ±0.5 V
Collector Q3	+21.4 V ±1.0 V

NOTE: Preamplifier voltages are negative for Serial Numbers below 737-00456.

Table 5-7. Meter Amplifier Voltages

CHECK POINT	VOLTAGE
Emitter Q10	-0.64 V \pm 0.1 V
Collector Q10	+9.20 V \pm 2.0 V
Collector Q11	+0.97 V \pm 0.2 V
Collector Q12	+22.00 V \pm 2.0 V
Collector Q13	+11.00 V \pm 1.0 V
Collector Q15	+2.30 V \pm 0.5 V

5-50. METER BRIDGE.

5-51. Measure the dc voltages on the transistors in the meter bridge and compare the readings with those given in Table 5-8. Also measure the voltages at the meter terminals. The meter should be floating at approximately -9 volts, \pm 2 volts, with respect to circuit ground.

Table 5-8. Meter Bridge Voltages

CHECK POINT	VOLTAGE
Collector Q16	-9 V \pm 2 V
Base Q17	-17 V \pm 1 V

5-52. **ETCHED CIRCUIT BOARD REPAIR.**

5-53. The Model 400GL uses plated-through, double-sided, etched circuit boards. To prevent damage to the circuit board and components, observe the following rules when soldering:

- a. Use a low-heat (25 to 50 watts) soldering iron with a small tip (1/16" to 3/32" diameter).

- b. To remove a component, clip a heat sink (long nose pliers, commercial heat sink tweezers, etc.) on the component lead as close to the component as possible. Place the soldering iron directly on the component lead, and pull up on the lead. If a component is obviously damaged or faulty, clip the leads close to the component and then remove the leads from the board.



EXCESSIVE OR PROLONGED HEAT CAN LIFT THE CIRCUIT FOIL FROM THE BOARD OR CAUSE DAMAGE TO COMPONENTS.

- c. Clean the component lead holes by heating the solder in the hole, quickly removing the soldering iron, and inserting a pointed, non-metallic object such as a toothpick.
- d. To mount a new component, shape the leads and insert them in the holes. Clip a heat sink on the component, heat with the soldering iron, and add solder as necessary to obtain a good electrical connection.
- e. Clip excess leads off after soldering and clean excess flux from the connection and adjoining area, using type TF Freon (-hp- Part No. 8500-0232).

SECTION VI CIRCUIT DIAGRAMS

6-1. INTRODUCTION.

6-2. This section contains the schematic and component location diagrams for the Model 400GL. Figure 6-1 shows a flattened view of the RANGE switch and part of the internal wiring data. Fig-

ure 6-2 shows the component location on the A1 and A2 printed circuit boards, and the location of chassis components. Figure 6-3 is the schematic diagram of the 400GL.

An explanation of terms and symbols used as reference designators is given below.

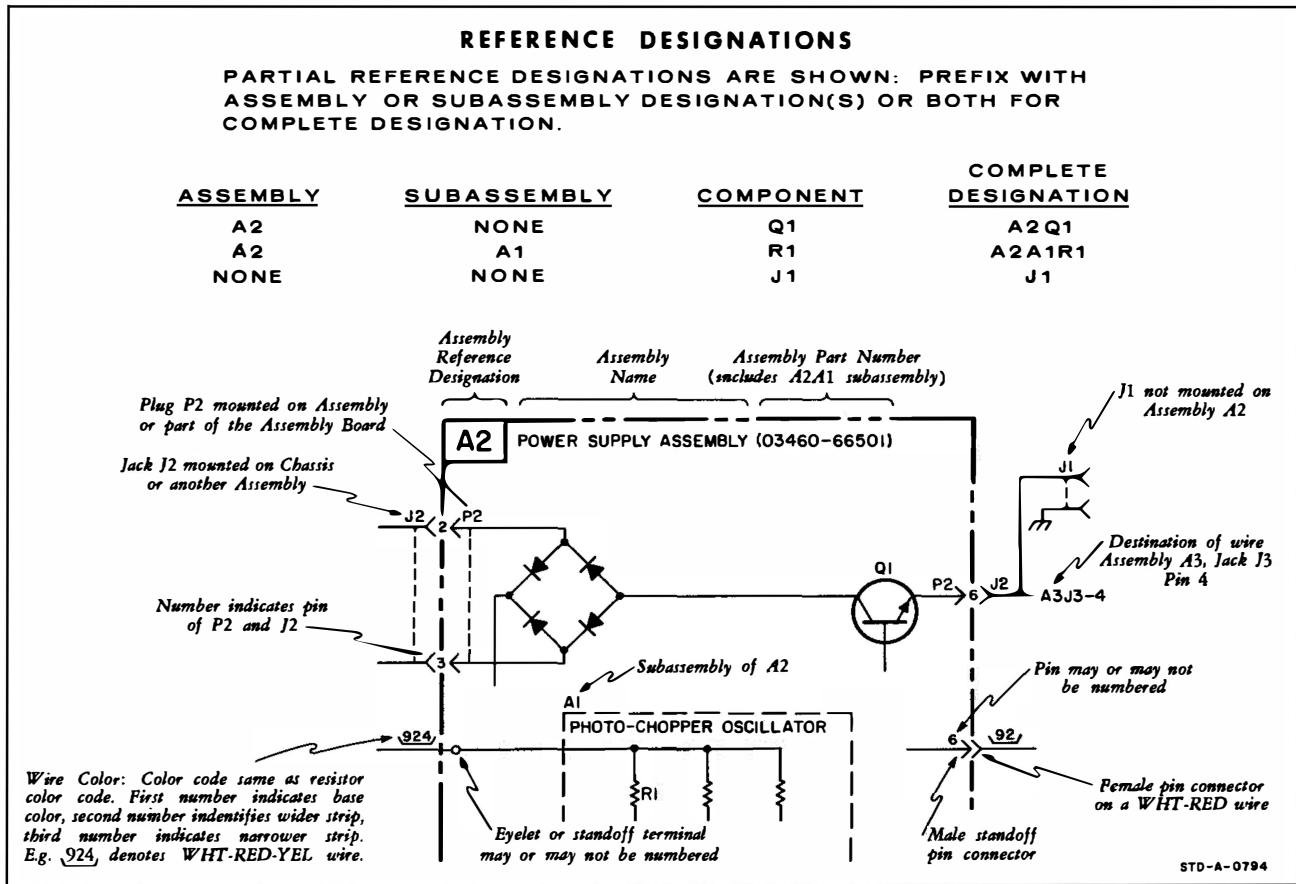

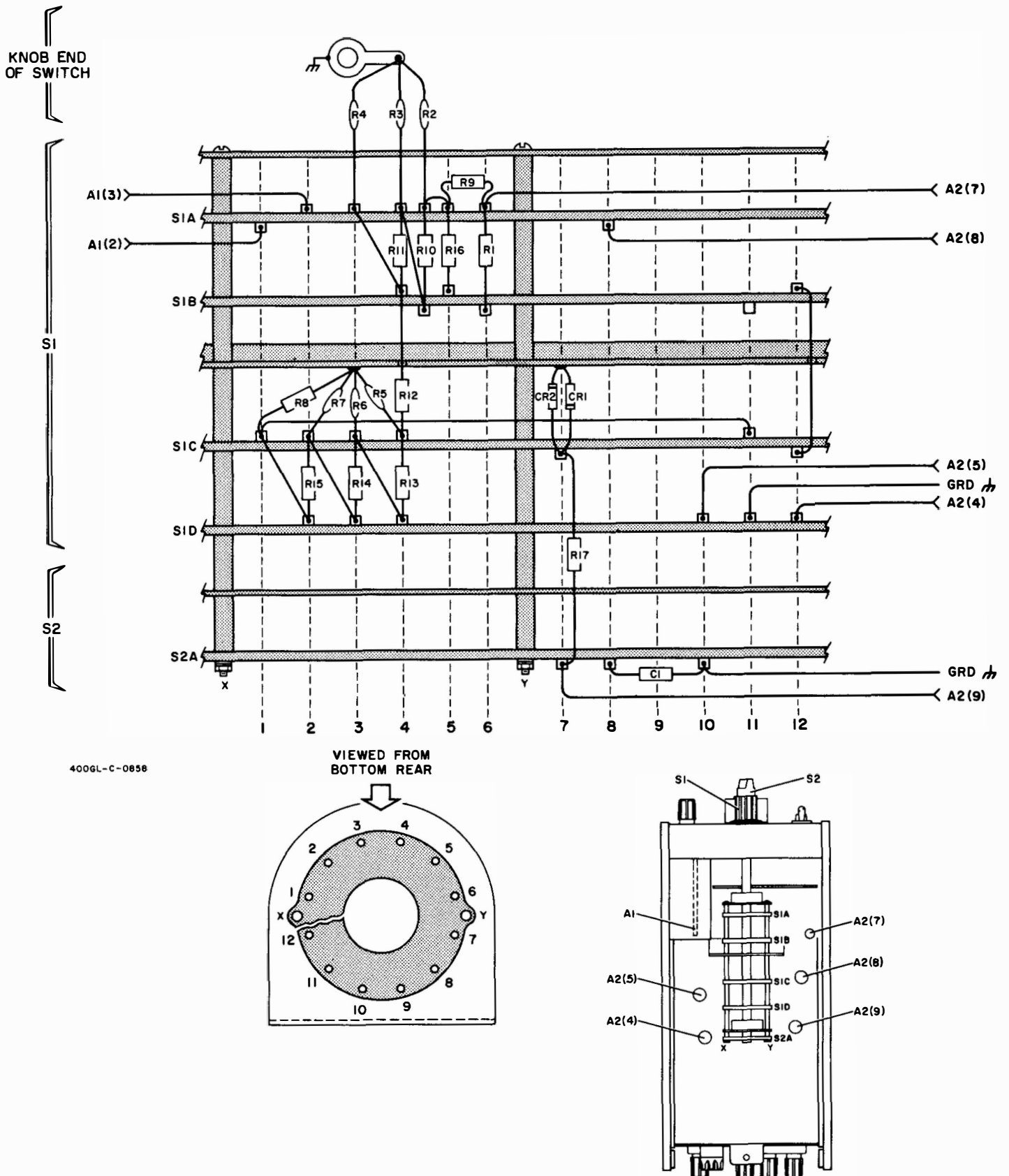

400GL-C-0858

VIEWED FROM
BOTTOM REAR

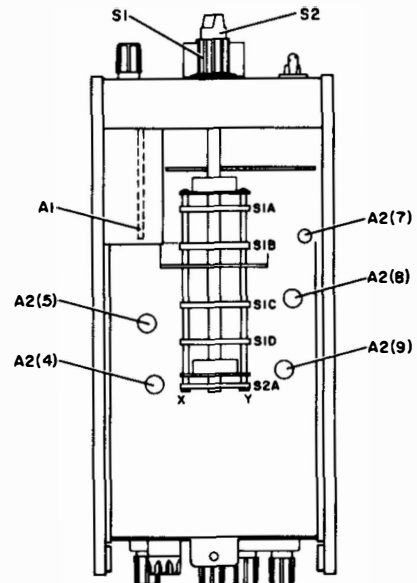
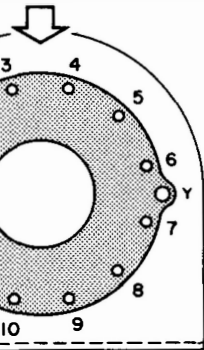

Figure 6-1. Model 400GL Range Switch

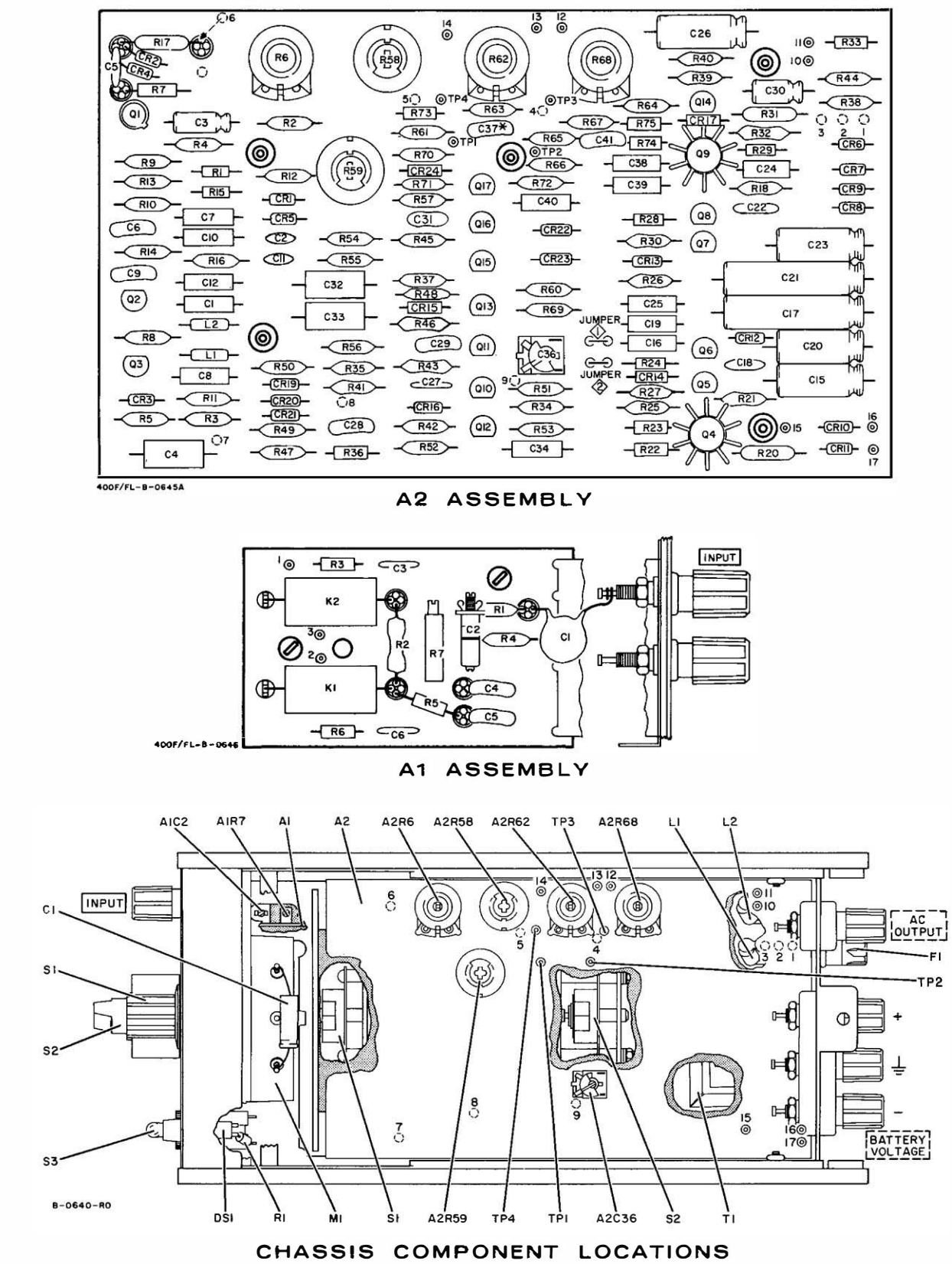
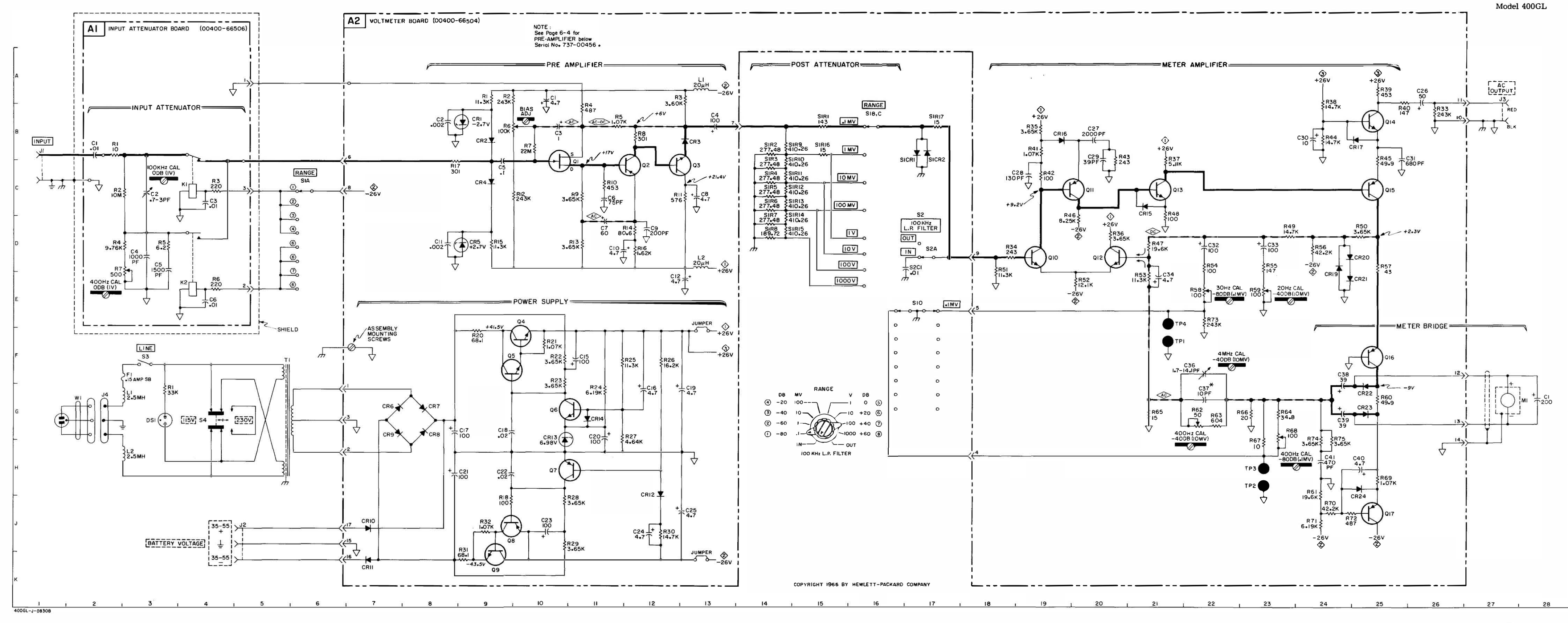

Figure 6-2. Model 400GL Component Location



- NOTES
- PARTIAL REFERENCE DESIGNATIONS ARE SHOWN. PREFIX WITH ASSEMBLY OR SUBASSEMBLY DESIGNATION(S) OR BOTH FOR COMPLETE DESIGNATION.
 - COMPONENT VALUES ARE SHOWN AS FOLLOWS UNLESS OTHERWISE NOTED.
RESISTANCE IN OHMS
CAPACITANCE IN MICROFARADS
 - ⊥ DENOTES POWER LINE GROUND.
⏏ DENOTES CHASSIS GROUND.
▽ DENOTES SIGNAL COMMON.
 - DENOTES ASSEMBLY.
--- DENOTES MAIN SIGNAL PATH.
--- DENOTES FEEDBACK PATH.
 - DENOTES FRONT PANEL MARKING.
--- DENOTES REAR PANEL MARKING.
 - ⊕ DENOTES SCREWDRIVER ADJUST.
 - * AVERAGE VALUE SHOWN, OPTIMUM VALUE SELECTED AT FACTORY.

A2 SCHEMATIC COMPONENT LOCATIONS

C	CR	Q	R	L	R
1	A10	B9	C11	A9	43
2	B8	B9	C12	A9	D13
3	B10	B13	C13	A13	44
					B25
4	B13	C8	E10	B11	46
5	C9	D8	F9	B11	47
6	C11	G7	G10	B9	48
7	D11	G8	H10	B10	49
8	C13	G8	J9	B12	50
9	D12	G7	K9	C11	51
10	D11	J7	D19	C11	52
11	D6	K7	C20	C13	D21
12	E12	H12	D20	C10	54
13	--	G10	C21	D11	55
14	--	G11	B25	D12	56
15	F11	C21	C25	D9	D25
16	G12	B19	F25	D12	58
17	G9	B25	J25	C8	E23
18	G9	C25	J9	C8	G25
19	G13	E24	--	H1	H24
20	G11	D25	F9	G2	G22
21	H9	E25	F10	G2	F10
22	H9	G25	F10	G2	C23
23	J10	G25	F10	G2	C21
24	J12	J25	--	G2	66
25	J13	F12	--	H1	H23
26	A26	F12	--	H1	G23
27	B20	G12	--	H1	H25
28	C19	J11	--	J1	J24
29	B20	J11	--	J1	J24
30	E24	J12	--	J1	J24
31	B26	J9	--	J9	E22
32	I22	J9	--	J9	G24
33	D23	B25	--	J9	B25
34	E21	--	D18	--	76
35	F22	--	B19	--	78
36	F22	--	D20	--	78
37	G23	C21	--	J9	79
38	F24	A24	--	J9	80
39	G24	A25	--	J9	61
40	H25	H25	--	J9	82
41	H24	B19	--	J9	83
42	--	C19	--	J9	84

Figure 6-3. Model 400GL Schematic Diagram

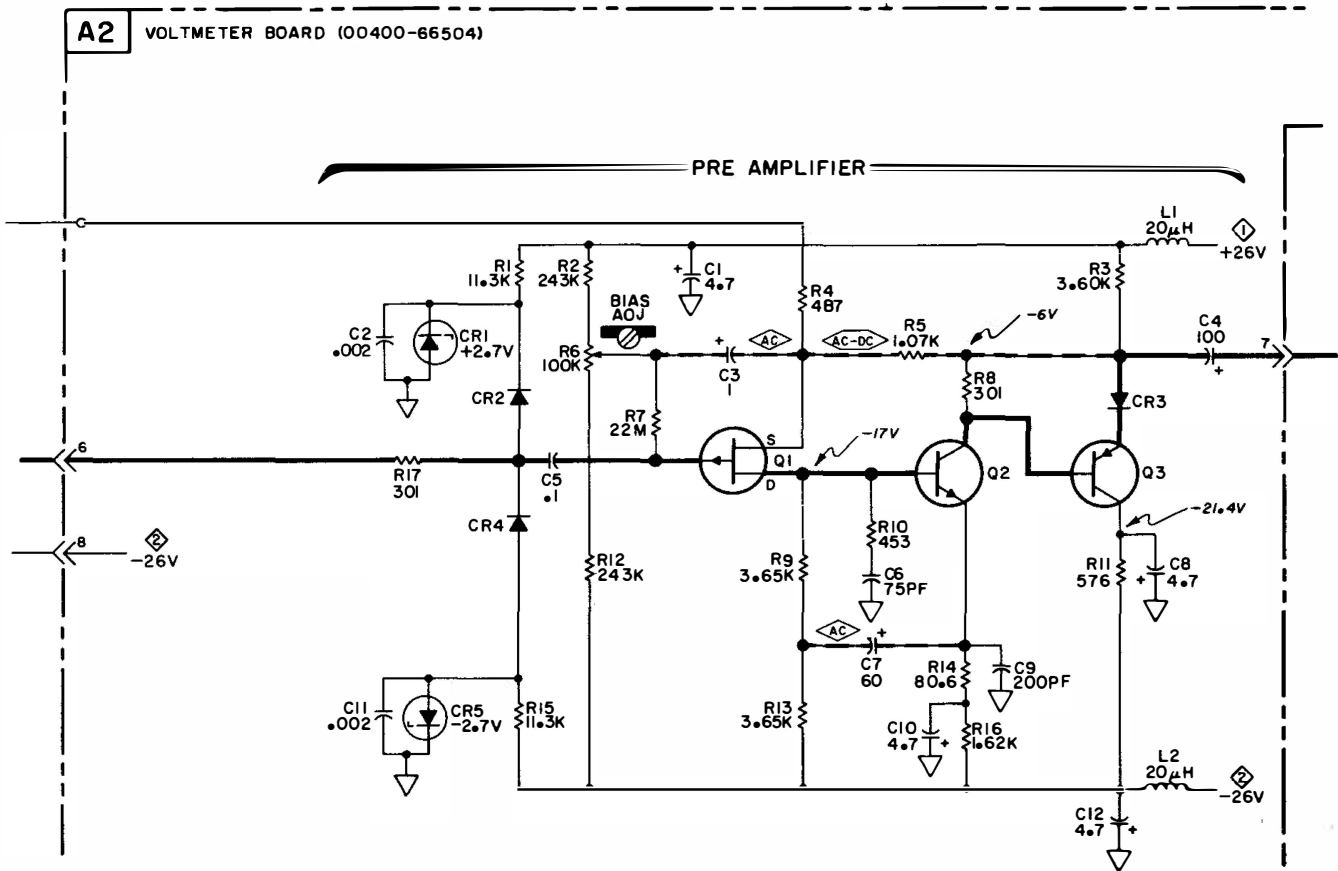

Figure 6-4. Pre Amplifier below Serial No. 737-00456

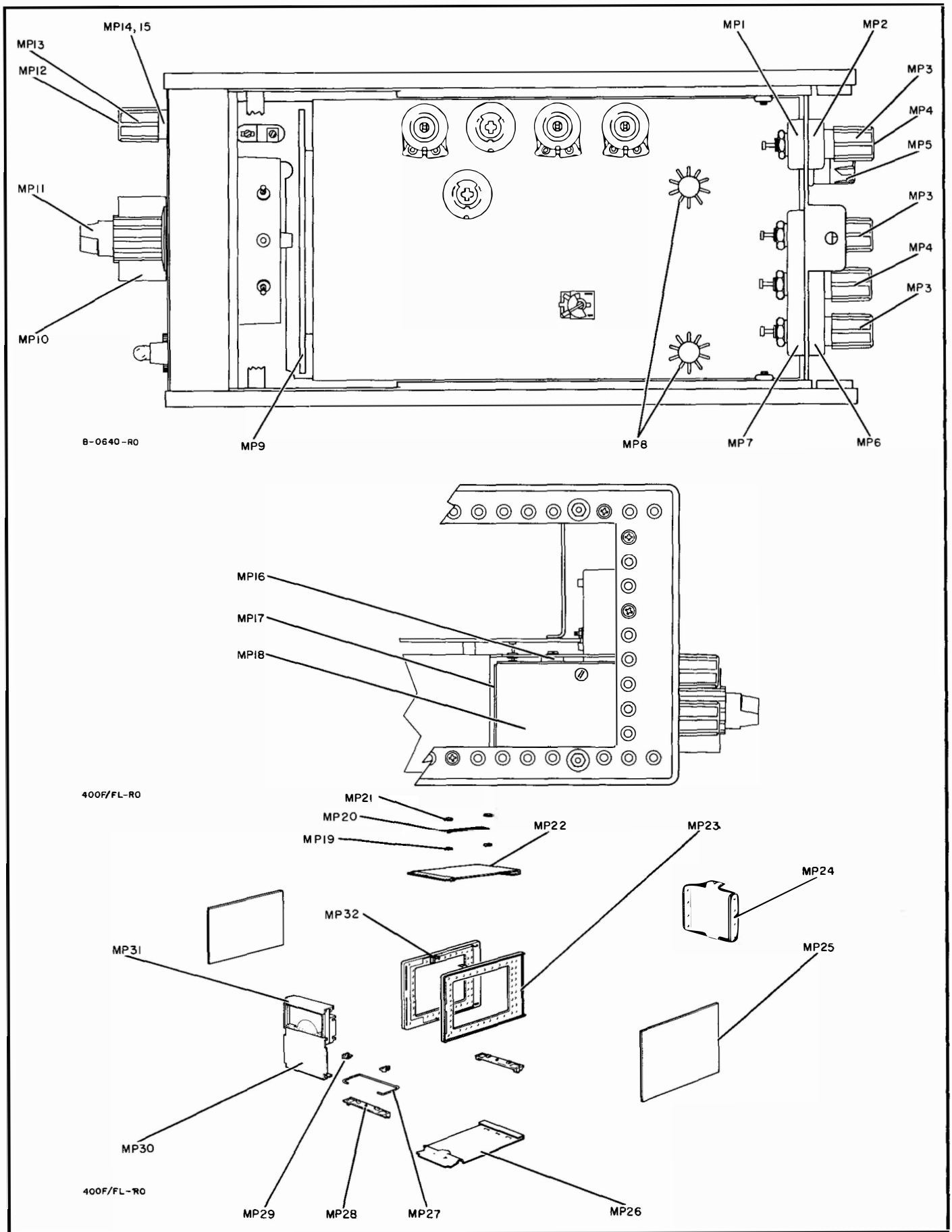

Figure 7-1. Location of Important Mechanical Parts

SECTION VII REPLACEABLE PARTS

7-1. INTRODUCTION.

7-2. This section contains information for ordering replacement parts. Table 7-1 lists parts in alphabetic order of their reference designators and indicates the description, -hp- part number of each part, together with any applicable notes, and provides the following:

- a. Total quantity used in the instrument (TQ column). The total quantity of a part is given the first time the part number appears.
- b. Description of the part. (See list of abbreviations below.)
- c. Typical manufacturer of the part in a five-digit code. (See Appendix A for list of manufacturers.)
- d. Manufacturer's part number.

7-3. Miscellaneous parts are listed at the end of Table 7-1.

7-4. ORDERING INFORMATION.

7-5. To obtain replacement parts, address order or inquiry to your local Hewlett-Packard Field Office. (See Appendix B for list of office locations.) Identify parts by their Hewlett-Packard part numbers. Include instrument model and serial numbers.

7-6. NONLISTED PARTS.

7-7. To obtain a part that is not listed, include:

- a. Instrument model number.
- b. Instrument serial number.
- c. Description of the part.
- d. Function and location of the part.

DESIGNATORS

A = assembly	F = fuse	MP = mechanical part	TC = thermocouple
B = motor	FL = filter	P = plug	V = vacuum tube, neon bulb, photocell, etc.
BT = battery	HR = heater	Q = transistor	W = cable
C = capacitor	IC = integrated circuit	QCR = transistor-diode	X = socket
CR = diode	J = jack	R = resistor	XDS = lampholder
DL = delay line	K = relay	RT = thermistor	XF = fuseholder
DS = lamp	L = inductor	S = switch	Z = network
E = misc electronic part	M = meter	T = transformer	

ABBREVIATIONS

Ag = silver	ID = inside diameter	na = nanosecond (s) = 10 ⁻⁹ seconds	sl = slide
Al = aluminum	impG = impregnated	nar = not separately replaceable	SPDT = single-pole double-throw
A = ampere (s)	incd = incandescent	Ω = ohm (s)	Ta = tantalum
Au = gold	ina = insulation (ed)	obd = order by description	TC = temperature coefficient
C = capacitor	kΩ = kilohm (s) = 10 ⁺³ ohms	OD = outside diameter	TiO ₂ = titanium dioxide
cer = ceramic	kHs = kilohertz = 10 ⁺³ hertz	P = peak	log = toggle
coef = coefficient	L = inductor	pc = printed circuit	tol = tolerance
com = common	lin = linear taper	pF = picofarad (s) = 10 ⁻¹² farads	trim = trimmer
comp = composition	log = logarithmic taper	µA = microampere (s) = 10 ⁻⁶ amperes	TSTR = transistor
conn = connection	m = milli = 10 ⁻³	piv = peak inverse voltage	V = volt (s)
dep = deposited	mA = milliampere (s) = 10 ⁻³ amperes	p/o = part of	vacw = alternating current working voltage
DPDT = double-pole double-throw	MHz = megahertz = 10 ⁺⁶ hertz	pos = position (s)	var = variable
DPST = double-pole single-throw	MΩ = megohm-(s) = 10 ⁺⁶ ohms	pot = potentiometer	vdw = direct current working voltage
elect = electrolytic	met film = metal film	p-p = peak-to-peak	W = watt (s)
encap = encapsulated	mfr = manufacturer	ppm = parts per million	w/ = with
F = farad (s)	mg = mounting	prec = precision (temperature coefficient, long term stability, and/or tolerance)	wiv = working inverse voltage
FET = field effect transistor	mV = millivolt (s) = 10 ⁻³ volts	R = resistor	w/o = without
fxd = fixed	µV = microvolt (s) = 10 ⁻⁶ volts	Rh = rhodium	ww = wirewound
GaAs = gallium arsenide	µ = microliter	rms = root-mean-square	* = optimum value selected at factory, average value shown (part may be omitted)
GHz = gigahertz = 10 ⁺⁹ hertz	my = Mylar [®]	rot = rotary	** = no standard type number assigned (selected or special type)
gd = guard (ed)	nA = nanoampere (s) = 10 ⁻⁹ amperes	S = selenium	
Ge = germanium	NC = normally closed	sect = section (s)	
grd = ground (ed)	Ne = neon	Si = silicon	
H = heavy (seal)	NO = normally open		
Hg = mercury	NPO = negative positive zero (zero temperature coefficient)		
Hz = hertz (cycle (s) per second)			

[®] Dupont de Nemours

Table 7-1. Replaceable Parts

REFERENCE DESIGNATOR	-hp- PART NO.	TQ	DESCRIPTION	MFR.	MFR. PART NO.
A 1	00400-66506 00400-66505	1	Board: etched circuit input assembly (below Serial Number 737-00456)	28480 28480	00400-66506 00400-66505
A1C1	0150-0012	1	C: fxd cer 0.01 μ F \pm 20% 1000 vdcw	56289	29C214A3
A1C2	0121-0407	1	C: var trim 0.7 to 3 pF	72982	536-016
A1C3	0150-0093	1	C: fxd cer 0.01 μ F +80% -20% 100 vdcw	91418	TA obd
A1C4	0140-0179	1	C: fxd mica 1000 pF \pm 2%	04062	RDM19F102G3C
A1C5	0140-0156	1	C: fxd mica 1500 pF \pm 2%	04062	RDM19F152G3C
A1C6	0150-0093	2	C: fxd cer 0.01 μ F +80% -20% 100 vdcw	91418	TA obd
A1K1	0490-0479 0490-0478 0490-0195	1	Relay reed: high voltage K1 (below Serial Number 737-00456) (below Serial Number 628-00151)	28480 28480 28480	0490-0479 0490-0478 0490-0195
A1K2	0490-0343	1	Relay reed: low voltage K2	28480	0490-0343
A1R1	0757-0346	1	R: fxd prec met flm 10.0 M Ω \pm 1% 1/8 W	19701	MF5C T-O obd
A1R2	0698-4128	1	R: fxd met flm 10.0 M Ω \pm 0.25% 1/2 W	03888	PME70-T-2 obd
A1R3	0684-2211	2	R: fxd comp 220 Ω \pm 10% 1/4 W	01121	CB 2211 obd
A1R4	0698-4475	1	R: fxd prec met flm 9760 Ω \pm 1% 1/8 W	19701	MF5C T-O obd
A1R5	0683-0625	1	R: fxd comp 6.2 Ω \pm 5% 1/4 W	01121	CB-62G5 obd
A1R6	0684-2211	1	R: fxd comp 220 Ω \pm 10% 1/4 W	01121	CB2211 obd
A1R7	2100-1799	1	R: var pot ww 500 Ω \pm 10% 1 W	89709	2600 Series obd
A2	00400-66504	1	Board: etched circuit assembly	28480	00400-66504
A2C1	0180-0100	10	C: fxd Ta 4.7 μ F \pm 10% 35 vdcw	56289	150D475X9035B2
A2C2	0150-0122	3	C: fxd cer 0.002 μ F \pm 20% 500 vdcw	72982	Style 801-000-Y5S-202M
A2C3	0180-0119	1	C: fxd Al elect 1 μ F +75% -10% 25 vdcw	56289	30D105G025BA2-DSM
A2C4	0180-0137	3	C: fxd Ta elect 100 μ F 10 vdcw	56289	150D107X0010R2
A2C5	0150-0084	1	C: fxd cer 0.1 μ F +80% -20% 50 vdcw	56289	33C41 obd
A2C6	0160-2024	1	C: fxd mica 75 pF \pm 5% 500 vdcw	04062	RDM15E750J5S
A2C7	0180-0106	1	C: fxd Ta elect 60 μ F \pm 20% 6 vdcw	56289	150D606X0006B2
A2C8	0180-0100	1	C: fxd Ta 4.7 μ F \pm 10% 35 vdcw	56289	150D475X9035B2
A2C9	0140-0198	1	C: fxd mica 200 pF \pm 5%	04062	RDM15F201J3C
A2C10	0180-0100	1	C: fxd Ta 4.7 μ F \pm 10% 35 vdcw	56289	150D475X9035B2
A2C11	0150-0122	1	C: fxd cer 0.002 μ F \pm 20% 500 vdcw	72982	Style 801-000-Y5S-202M
A2C12	0180-0100	1	C: fxd Ta 4.7 μ F \pm 10% 35 vdcw	56289	150D475X9035B2
A2C13, A2C14			Not assigned		
A2C15	0180-0061	3	C: fxd Al elect 100 μ F +75% -10% 15 vdcw	56289	30D107G015DC2-DSM
A2C16	0180-0100	1	C: fxd Ta 4.7 μ F \pm 10% 35 vdcw	56289	150D475X9035B2
A2C17	0180-1819	2	C: fxd Al elect 100 μ F +75% -10% 50 vdcw	56289	30D107G050DH2-DSM
A2C18	0150-0024	2	C: fxd cer 0.02 μ F +80% -20% 600 vdcw	71590	841-000-Z5U-203Z
A2C19	0180-0100	1	C: fxd Ta 4.7 μ F \pm 10% 35 vdcw	56289	150D475X9035B2
A2C20	0180-0061	1	C: fxd Al elect 100 μ F +75% -10% 15 vdcw	56289	30D107G015DC2-DSM
A2C21	0180-1819	1	C: fxd Al elect 100 μ F +75% -10% 50 vdcw	56289	30D107G050DH2-DSM
A2C22	0150-0024	1	C: fxd cer 0.02 μ F +80% -20% 600 vdcw	71590	841-000-Z5U-203Z
A2C23	0180-0061	1	C: fxd Al elect 100 μ F +75% -10% 15 vdcw	56289	30D107G015DC2-DSM
A2C24, A2C25	0180-0100	1	C: fxd Ta 4.7 μ F \pm 10% 35 vdcw	56289	150D475X9035B2
A2C26	0180-0058	1	C: fxd Al elect 50 μ F +75% -10% 25 vdcw	56289	30D506G025CC2-DSM
A2C27	0150-0122	1	C: fxd cer 0.002 μ F \pm 20% 500 vdcw	72982	Style 801-000-Y5S-202M
A2C28	0140-0195	1	C: fxd mica 130 pF \pm 5%	04062	RDM15F131J3C
A2C29	0140-0190	1	C: fxd mica 39 pF \pm 5%	04062	RDM15E390J3C
A2C30	0180-0224	1	C: fxd Al elect 10 μ F +75% -10% 15 vdcw	56289	30D106G015BA4

Table 7-1. Replaceable Parts (Cont'd)

REFERENCE DESIGNATOR	-hp- PART NO.	TQ	DESCRIPTION	MFR.	MFR. PART NO.
A2C31 A2C32, A2C33 A2C34 A2C35	0140-0208 0180-0137 0180-0100	1	C: fxd mica 680 pF ±5% C: fxd Ta elect 100 μF 10 vdcw C: fxd Ta 4.7 μF ±10% 35 vdcw Not assigned	04062 56289 56289	RDM 15F681J3C 150D107X0010R2 150D475X9035B2
A2C36 A2C37 A2C38, A2C39 A2C40 A2C41	0121-0127 0160-0205 0180-0393 0180-0100 0140-0149	1 1 2 1	C: var air trim 1.7 to 14.1 pF C: fxd mica 10 pF ±5% C: fxd Ta 39 μF ±10% 10 vdcw C: fxd Ta 4.7 μF ±10% 35 vdcw C: fxd mica 470 pF ±5%	74970 04062 56289 56289 04062	189-505-5 RDM15C 100J5S 150D396X9010B2 150D475X9035B2 RDM 15F471J3S
A2CR1 A2CR2	1902-0022 1901-0044	2 2	Diode: 2.67 V ±10% Diode: Si 20 mA at +1V 10 nA at 10Vreverse current 50 wiv 2 pF	04713 03877	SZ10939-16 SG5178 obd SG5050 obd
A2CR3 A2CR4 A2CR5	1901-0040 1901-0044 1902-0022	10	Diode: Si 30 wV 30 mA 2 pF Diode: Si 20 mA +1 V 10 nA 10 V 50 wiv 2 pF Diode: 2.67 V ±10%	03877 03877 04713	SG5178 obd SG5178 obd SZ 10939-16
A2CR6 thru A2CR11 A2CR12 A2CR13 A2CR14, A2CR15	1901-0033 1901-0040 1902-3125 1901-0040	6 1	Diode: Si 100 mA at +1V 180 wiv 13 pF Diode: Si 30 wV 30 mA 2 pF Diode: Si breakdown V 6.98 V ±2% Diode: Si 30 wV 30 mA 2 pF	03877 03877 07263 03877	SG3396 obd SG5050 obd obd SG5050 obd
A2CR16 A2CR17	1901-0040 1901-0040		Diode: Si 30 wV 30 mA 2 pF Diode: Si 30 wV 30 mA 2 pF	03877 03877	SG5050 obd SG5050 obd
A2CR19 thru A2CR21 A2CR22, A2CR23 A2CR24 A2L1, A2L2 A2Q1	1901-0040 1901-0027 1901-0040 9140-0047 1855-0033 1855-0029	2 2 1	Diode: Si 1 pF 10 wiv Diode: Si 30 wV 30 mA 2 pF Inductor: fxd 20 μH ±10% TSTR: Si 2N3684 TSTR: F5035 FET** (below Ser. No.737-00456)	73293 03877 99848 07256 28480	obd SG5050 obd H51074020 FN576 1855-0029
A2Q2	1853-0036 1854-0215	7	TSTR: Si PNP 2N3906 TSTR: SiNPN2N3904(below Ser. No. 737-00456)	04713 04713	SPS-3612 2N3904 obd
A2Q3	1854-0314 1853-0036	7	TSTR: SiNPN2N3904 TSTR: Si PNP 2N3906 (below Ser. No. 737-00456)	04713 04713	MPS6521-5 2N3906
A2Q4 A2Q5, A2Q6 A2Q7, A2Q8 A2Q9 A2Q10 A2Q11 A2Q12 thru A2Q14 A2Q15 thru A2Q17	1854-0039 1854-0215 1853-0036 1854-0039 1854-0215 1853-0036 1854-0215 1853-0036	2	TSTR: Si NPN 2N3053 TSTR: Si NPN 2N3904 TSTR: Si PNP 2N3906 TSTR: Si NPN 2N3053 TSTR: Si NPN 2N3904 TSTR: Si PNP 2N3906 TSTR: Si NPN 2N3904	04713 04713 04713 04713 04713 04713 04713	2N3053 obd 2N3904 obd 2N3906 obd 2N3053 obd 2N3904 obd 2N3906 obd
A2R1 A2R2 A2R3 A2R4	0698-4121 0757-0474 0686-3625 0698-3178	5 4 12 2	R: fxd prec met flm 11.3 KΩ ±1% 1/6 W R: fxd prec met flm 243 KΩ ±1% 1/8 W R: fxd 3.60 kΩ ±5% 1/2 W R: fxd prec met flm 487 Ω ±1% 1/8 W	19701 75042 01121 19701	MF5C T-O obd CEA T-O obd EB3625 MF5C T-O obd
A2R5 A2R6 A2R7 A2R8	0698-4196 2100-0095 0686-2265 0757-0410	5 1 1 1	R: fxd prec met flm 1070 Ω ±1% 1/8 W R: var pot comp 100 KΩ ±30% 0.10 W R: fxd comp 22 MΩ ±5% 1/2 W R: fxd prec met flm 301 Ω ±1% 1/8 W	19701 11236 01121 19701	MF5C T-O obd UPM70RE(-hp-)obd EB2265 obd MF5C T-O obd
A2R9 A2R10 A2R11	0757-0434 0698-3510 0698-4457	2 1	R: fxd prec met flm 3650 Ω 1/8 W R: fxd prec met flm 453 Ω ±1% 1/8 W R: fxd prec met flm 576 Ω ±1% 1/8 W	19701 19701 19701	MF5C T-O obd MF5C T-O obd MF5C T-O obd

Table 7-1. Replacable Parts (Cont'd)

REFERENCE DESIGNATOR	-hp- PART NO.	TQ	DESCRIPTION	MFR.	MFR. PART NO.
A2R12	0757-0474		R: fxd prec met flm 243 K Ω \pm 1% 1/8 W	75042	CEA T-O obd
A2R13	0757-0434		R: fxd prec met flm 3650 Ω \pm 1% 1/8 W	19701	MF5C T-O obd
A2R14	0698-4396	2	R: fxd prec met flm 80.6 Ω \pm 1% 1/6 W	19701	MF5C T-O obd
A2R15	0698-4121		R: fxd prec met flm 11.3 K Ω \pm 1% 1/8 W	19701	MF5C T-O obd
A2R16	0757-0428	1	R: fxd prec 1620 Ω \pm 1% 1/8 W	19701	MF5C T-O obd
A2R17	0757-0808	1	R: fxd prec met flm 301 Ω \pm 1% 1/2 W	75042	CEC T-O obd
A2R18	0757-0401	5	R: fxd prec met flm 100 Ω \pm 1% 1/8 W	19701	MF5C T-O obd
A2R19			Not assigned		
A2R20	0757-0794	2	R: fxd prec met flm 68.1 Ω \pm 1% 1/2 W	75042	CEA T-O obd
A2R21	0698-4196		R: fxd prec met flm 1070 Ω \pm 1% 1/8 W	19701	MF5C T-O obd
A2R22, A2R23	0757-0434		R: fxd prec met flm 3650 Ω \pm 1% 1/8 W	19701	MF5C T-O obd
A2R24	0757-0290	2	R: fxd prec met flm 6.190 Ω \pm 1% 1/8 W	75042	CEA T-O obd
A2R25	0698-4121		R: fxd prec met flm 11.3 K Ω \pm 1% 1/8 W	19701	MF5C T-O obd
A2R26	0757-0447	1	R: fxd prec met flm 16.2 K Ω \pm 1% 1/8 W	19701	MF5C T-O obd
A2R27	0698-3155	1	R: fxd prec met flm 4640 Ω \pm 1% 1/8 W	19701	MF5C T-O obd
A2R28, A2R29	0757-0434		R: fxd prec met flm 3650 Ω \pm 1% 1/8 W	19701	MF5C T-O obd
A2R30	0698-3156	4	R: fxd prec met flm 14.7 K Ω \pm 1% 1/8 W	75042	CEA T-O obd
A2R31	0757-0794		R: fxd prec met flm 68.1 Ω \pm 1% 1/2 W	75042	CEA T-O obd
A2R32	0698-4196		R: fxd prec met flm 1070 Ω \pm 1% 1/8 W	19701	MF5C T-O obd
A2R33	0757-0474		R: fxd prec met flm 243 K Ω \pm 1% 1/8 W	75042	CEA T-O obd
A2R34	0757-0408		R: fxd prec met flm 243 Ω \pm 1% 1/8 W	19701	MF5C T-O obd
A2R35, A2R36	0757-0434		R: fxd prec met flm 3650 Ω \pm 1% 1/8 W	19701	MF5C T-O obd
A2R37	0757-0438	1	R: fxd prec met flm 5110 Ω \pm 1% 1/8 W	75042	CEA T-O obd
A2R38	0698-3156		R: fxd prec met flm 14.7 K Ω \pm 1% 1/8 W	75042	CEA T-O obd
A2R39	0698-3510		R: fxd prec met flm 453 Ω \pm 1% 1/8 W	19701	MF5C T-O obd
A2R40	0698-3438	2	R: fxd prec met flm 147 Ω \pm 1% 1/8 W	19701	MF5C T-O obd
A2R41	0698-4196		R: fxd prec met flm 1070 Ω \pm 1% 1/8 W	19701	MF5C T-O obd
A2R42	0757-0401		R: fxd prec met flm 100 Ω \pm 1% 1/8 W	19701	MF5C T-O obd
A2R43	0757-0408	2	R: fxd prec met flm 243 Ω \pm 1% 1/8 W	19701	MF5C T-O obd
A2R44	0698-3156		R: fxd prec met flm 14.7 K Ω \pm 1% 1/8 W	75042	CEA T-O obd
A2R45	0757-0277	1	R: fxd prec met flm 49.9 Ω \pm 1% 1/8 W	75042	CEA T-O obd
A2R46	0757-0441	1	R: fxd prec met flm 8250 Ω \pm 1% 1/8 W	19701	MF5C T-O obd
A2R47	0698-3157	2	R: fxd prec met flm 19.6 K Ω \pm 1% 1/8 W	19701	MF5C T-O obd
A2R48	0757-0401		R: fxd prec met flm 100 Ω \pm 1% 1/8 W	19701	MF5C T-O obd
A2R49	0698-3156		R: fxd prec met flm 14.7 K Ω \pm 1% 1/8 W	75042	CEA T-O obd
A2R50	0757-0434		R: fxd prec met flm 3650 Ω \pm 1% 1/8 W	19701	MF5C T-O obd
A2R51	0698-4121		R: fxd prec met flm 11.3 K Ω \pm 1% 1/8 W	19701	MF5C T-O obd
A2R52	0757-0444	1	R: fxd prec met flm 12.1 K Ω \pm 1% 1/8 W	19701	MF5C T-O obd
A2R53	0698-4121		R: fxd prec met flm 11.3 K Ω \pm 1% 1/8 W	19701	MF5C T-O obd
A2R54	0757-0401		R: fxd prec met flm 100 Ω \pm 1% 1/8 W	19701	MF5C T-O obd
A2R55	0698-3438		R: fxd prec met flm 147 Ω \pm 1% 1/8 W	19701	MF5C T-O obd
A2R56	0698-3450	2	R: fxd prec met flm 42.2 K Ω \pm 1% 1/8 W	19701	MF5C T-O obd
A2R57	0757-0408		R: fxd prec met flm 243 Ω \pm 1% 1/8 W	19701	MF5C T-O obd
A2R58, A2R59	2100-0290	2	R: var ww 100 Ω \pm 20% 1-1/2 W	11237	110 obd
A2R60	0757-0277		R: fxd prec met flm 49.9 Ω \pm 1% 1/8 W	91637	MF-1/10-32
A2R61	0698-3157		R: fxd prec met flm 19.6 Ω \pm 1% 1/8 W	19701	MF5C T-O obd
A2R62	2100-0240	1	R: var ww 50 Ω \pm 20% 1-1/2 W	11237	110 obd
A2R63	0757-0161	1	R: fxd prec met flm 604 Ω \pm 1% 1/8 W	19701	MF5C T-O obd
A2R64	0698-3434	1	R: fxd prec met flm 34.8 Ω \pm 1% 1/8 W	75042	CEA T-O obd
A2R65	0757-0381	1	R: fxd prec met flm 15 Ω \pm 1% 1/8 W	75042	CEA T-O obd
A2R66	0757-0384	1	R: fxd prec met flm 20 Ω \pm 1% 1/8 W	75042	CEA T-O obd
A2R67	0757-0346	1	R: fxd prec met flm 10 Ω \pm 1% 1/8 W	75042	CEA T-O obd
A2R68	2100-0277	1	R: var comp lin 100 Ω \pm 20% 0.3 W	11236	Type UPE65CV obd
A2R69	0698-4196		R: fxd 1070 Ω \pm 1% 1/8 W	19701	MF5C T-O obd
A2R70	0698-3450		R: fxd prec met flm 42.2 K Ω \pm 1% 1/8 W	19701	MF5C T-O obd
A2R71	0757-0290		R: fxd prec met flm 6190 Ω \pm 1% 1/8 W	75042	CEA T-O obd
A2R72	0698-3178		R: fxd prec met flm 487 Ω \pm 1% 1/8 W	19701	MF5C T-O obd

Table 7-1. Replaceable Parts (Cont'd)

REFERENCE DESIGNATOR	-hp- PART NO.	TQ	DESCRIPTION	MFR.	MFR. PART NO.
A2R73	0757-0474		R: fxd prec met flm 243 K Ω \pm 1% 1/8 W	75042	CEA T-O obd
A2R74, A2R75	0757-0434		R: fxd prec met flm 3650 Ω \pm 1% 1/8 W	19701	MF5C T-O obd
C1	0180-0060	1	C: fxd Al elect 200 μ F +75% -10% 3 vdcw	56289	30D207G003CC2-DSM
DS1	1450-0048	1	Lamp: pilot 1" red transparent	72765	599-124 obd
F1	2110-0017	1	Fuse: 15 A slow-blow 115 V - 230 V	75915	313.150 obd
L1, L2	9140-0041	2	Inductor: fxd 30 Ω or less 2.5 mH \pm 10%	95265	SA-2500-1 obd
M1	1120-0928		Meter	28480	1120-0928
MP1	0340-0090	1	Insulator: 2 hole front with locating key	28480	0340-0090
MP2	0340-0086	1	Insulator: 2 hole rear	28480	0340-0086
MP3	1510-0010	3	Binding post assembly: red	28480	1510-0010
MP4	1510-0011	2	Binding post assembly: black	28480	1510-0011
MP5	1400-0084	1	Holder: fuse	75915	342014 obd
MP6	0340-0087	1	Insulator: 3 hole rear	28480	0340-0087
MP7	0340-0091	1	Insulator: 3 hole front	28480	0340-0091
MP8	1205-0033	2	Heat dissipator: semiconductor for TO-5	05820	NF-207 obd
MP9	00400-00605		Shield: meter	28480	00400-00605
MP10	0370-0113	1	Knob: bar with one arrow	28480	0370-0113
MP11	0370-0115	1	Knob: bar red w/ pointer	28480	0370-0115
MP12	1510-0035	1	Binding post assembly: black	28480	1510-0035
MP13	1510-0036	1	Binding post assembly: red	28480	1510-0036
MP14	0340-0099	2	Insulator: single binding post	28480	0340-0099
MP15	0340-0100	1	Insulator: single binding post	28480	0340-0100
MP16	0340-0109	6	Insulator: 6-32 nylon 0.437"	000LA	212-160402-00-0101
MP17	00400-05502	1	Can: shield input	28480	00400-05502
MP18	00400-04102	1	Cover: input attenuator	28480	00400-04102
MP19	1440-0050	2	Plate: handle plated steel	12136	Part 3 of 3 assy # 1875-376-370
MP20	1440-0049	2	Cap: handle brushed cadmium	12136	Part 2 of 3 assy # 1875-376-370
MP21	1440-0048	1	Strap: handle black vinyl	12136	Part 1 of 3 assy # 1875-376-370
MP22	5060-6020	1	Cover assembly: top 5 x 11 sub module	28480	5060-6020
MP23	5060-0703	2	Frame assembly: 6 x 11 sub module	28480	5060-0703
MP24	00400-00210	1	Panel: rear	28480	00400-00210
	00400-00206		(below Serial Number 943-01016)	28480	00400-00206
MP25	5000-0703	2	Side cover 6 x 11 sub module	28480	5000-0703
MP26	5000-0711	1	Cover assembly: bottom 5 x 11 sub module	28480	5000-0711
MP27	1490-0031	1	Stand: 1/3 module tilt	91260	obd
MP28	5060-0727	2	Foot assembly: 1/3 module	28480	5060-0727
MP29	5040-0700	2	Hinge: mold	28480	5040-0700
MP30	00400-00209	1	Panel: front	28480	00400-00209
MP31	5020-0704	1	Meter trim: third module	28480	5020-0704
R1	0687-3331	1	R: fxd comp 33 K Ω \pm 10% 1/2 W	01121	EB3331 obd
S1	00400-61904		Switch: assembly range	28480	00400-61904
S1C1	0160-0207	1	C: fxd my 0.01 μ F \pm 5% 200 vdcw	56289	192P10352-pts
S1CR1, S1CR2	1901-0040	2	Diode: Si	03877	SG5050 obd
S1R1	0757-0167	1	R: fxd prec met flm 143 Ω \pm 1% 1/4 W	19701	MF6C T-O obd
S1R2 thru S1R7	0698-4118	6	R: fxd prec met flm 277.48 Ω \pm 0.1% 1/4 W	75042	obd
S1R8	0698-4117	1	R: fxd prec met flm 189.72 Ω \pm 0.1% 1/4 W	75042	obd
S1R9 thru S1R15	0698-4119		R: fxd prec met flm 410.26 Ω \pm 0.1% 1/4 W	75042	obd
S1R16, S1R17	0687-1501	2	R: fxd comp 15 Ω \pm 10% 1/2 W	01121	EB1501 obd

Table 7-1. Replaceable Parts (Cont'd)

REFERENCE DESIGNATOR	-hp- PART NO.	TQ	DESCRIPTION	MFR.	MFR. PART NO.
S3	3101-0036	1	Switch: toggle 3 amps 250 V AC-DC	88140	8928K61
S4	3101-0033	1	Switch: slide 115/230	82389	11A-1009 obd
T1	00400-86901	1	Transformer	28480	00400-86901
W1	8120-1348 8120-0078		Cord: power, external (below Serial Number 943-01016)	70903 70903	obd obd
J4	1251-2357 1251-0148		Jack: rear panel, power (below Serial Number 943-01016)	28480 28480	1251-2357 1251-0148
MISCELLANEOUS					
	0340-0039	2	Bushing: insulator	00866	HP-3000T-1
	00400-61602	1	Cable 1: power	28480	00400-61602
	00400-61603	1	Cable 2: meter	28480	00400-61603
	0340-0060	3	Insulator: feed thru	98291	FT-E-15 obd
	0340-0060	7	Insulator: feed thru	92891	FT-E-15 obd
	0340-0059	2	Post: terminal	00866	obd
	0360-0435	4	Post: terminal	00677	1012-3 obd
	0380-0059	1	Spacer: captive	00866	obd
	0380-0111	5	Spacer: captive	00866	0380-0111
	00400-01202	1	Strap: ground	28480	00400-01202

CODE LIST OF MANUFACTURERS

The following code numbers are from the Federal Supply Code for Manufacturers Cataloging Handbooks H4-1 (Name to Code) and H4-2 (Code to Name) and their latest supplements. The date of revision and the date of the supplements used appear at the bottom of each page. Alphabetical codes have been arbitrarily assigned to suppliers not appearing in the H4 Handbooks.

Code No.	Manufacturer	Address	Code No.	Manufacturer	Address	Code No.	Manufacturer	Address
00000	U. S. A. Common	Any supplier of U. S.	06636	Cosmo Plastic	Cleveland, Ohio	11534	Duncan Electronics Inc.	Casta Mesa, Calif.
00136	McCoy Electronics	Mount Holly Springs, Pa.		(c/o Electrical Spec. Co.)		11711	General Instrument Corp., Semiconductor Div., Products Group	Newark, N. J.
00213	Sage Electronics Corp.	Rockester, N. Y.	85624	Barber Colman Co.	Rockford, Ill.	11717	Imperial Electronic, Inc.	Buena Park, Calif.
00287	Cemco Inc.	Danielson, Conn.	03728	Tiffen Optical Co.	Roslyn Heights, Long Island, N. Y.	11870	Melabs, Inc.	Palo Alto, Calif.
00334	Humidial	Colton, Calif.	05729	Metro-Tel Corp.	Westbury, N. Y.	12040	National Semiconductor	Danbury, Conn.
00348	Microlon Co., Inc.	Valley Stream, N. Y.	05783	Stewart Engineering Co.	Santa Cruz, Calif.	12136	Philadelphia Handle Co.	Camden, N. J.
00373	Carlock Inc.	Cherry Hill, N. J.	05820	Wakefield Engineering Inc.	Wakefield, Mass.	12361	Phore Mfg. Co., Inc.	Sbady Grove, Pa.
00656	Aerovox Corp.	New Bedford, Mass.	06004	Bassick Co., Div. of Stewart Warner Corp.	Bridgeport, Conn.	12374	Gulton Ind. Inc. Data System Div.	Albuquerque, N. M.
00779	Amp. Inc.	Harrisburg, Pa.	06090	Raychem Corp.	Redwood City, Calif.	12697	Clarestat Mfg. Co.	Dover, N. H.
00781	Aircraft Radio Corp.	Boonton, N. J.	06175	Bausch and Lomb Optical Co.	Rochester, N. Y.	12728	Elmar Filter Corp.	W. Haven, Conn.
00815	Norther Engineering Laboratories, Inc.	Burlington, Wis.	06402	E. T. A. Products Co. of America	Chicago, Ill.	12859	Nippon Electric Co., Ltd.	Tokyo, Japan
00853	Sangamo Electric Co., Pickens Div.	Pickens, S. C.	06540	Amalab Electronic Hardware Co., Inc.	New Rochelle, N. Y.	12881	Metex Electronics Corp.	Craig, N. J.
00866	Goe Engineering Co.	City of Industry, Cal.	06555	Beede Electrical Instrument Co., Inc.	Penacook, N. H.	12930	Delta Semiconductor Inc.	Newport Beach, Calif.
00891	Carl E. Holmes Corp.	Los Angeles, Calif.	06866	General Devices Co., Inc.	Indianapolis, Ind.	12954	Dickson Electronics Corp.	Scottsdale, Arizona
00929	Microlab Inc.	Livingston, N. J.	06751	Components Inc., Ariz. Div.	Phoenix, Ariz.	13103	Thornolloy	Dallas, Texas
01002	General Electric Co., Capacitor Dept.	Hudson Falls, N. Y.	06812	Torrington Mfg. Co., West Div.	Van Nuys, Calif.	13396	Telefonken (GmbH)	Hanover, Germany
01009	Alden Products Co.	Stockton, Mass.	06980	Varian Assoc. Eimac Div.	San Carlos, Calif.	13395	Midland-Wright Div. of Pacific Industries, Inc.	Kansas City, Kansas
01121	Allen Bradley Co.	Milwaukee, Wis.	07088	Kelvin Electric Co.	Van Nuys, Calif.	14099	Sem-Tech	Newbury Park, Calif.
01255	Liton Industries, Inc.	Beverly Hills, Calif.	07126	Digilab Co.	Pasadena, Calif.	14193	Calil. Resistor Corp.	San Monica, Calif.
01281	TRW Semiconductors, Inc.	Lawndale, Calif.	07137	Transistor Electronics Corp.	Minneapolis, Minn.	14298	American Components, Inc.	Conshohocken, Pa.
01295	Texas Instruments, Inc., Transistor Products Div.	Dallas, Texas	07138	Westinghouse Electric Corp. Electronic Tube Div.	Elmira, N. Y.	14433	ITT Semiconductor, A Div. of Int. Telephone & Telegraph Corp.	West Palm Beach, Fla.
01349	The Alliance Mfg. Co.	Alliaco, Ohio	07149	Firmoh Corp.	New York, N. Y.	14493	Howlett-Packard Company	Loveland, Colo.
01589	Pacific Relays, Inc.	Van Nuys, Calif.	07233	Cinch-Graphik Co.	City of Industry, Calif.	14655	Cornell Dublier Electric Corp.	Newark, N. J.
01670	Gudebrod Bros. Silk Co.	New York, N. Y.	07256	Silicon Transistor Corp.	Carla Place, N. Y.	14674	Corning Glass Works	Corning, N. Y.
01930	Amerock Corp.	Rockford, Ill.	07261	Avnet Corp.	Calver City, Calif.	14752	Electro Cube Inc.	San Gabriel, Calif.
01963	Pulse Engineering Co.	Santa Clara, Calif.	07263	Fairchild Camera & Inst. Corp. Semiconductor Div.	Mountain View, Calif.	14960	Williams Mfg. Co.	Sao Jose, Calif.
02114	Ferroxcube Corp. of America	Saugerties, N. Y.	07322	Minnesota Rubber Co.	Minneapolis, Minn.	15203	Webster Electronics Co.	New York, N. Y.
02116	Wheelock Signals, Inc.	Long Branch, N. J.	07387	Birtcher Corp., The	Monterey Park, Calif.	15287	Scionics Corp.	Northridge, Calif.
02286	Cole Rubber and Plastics Inc.	Sunnyvale, Calif.	07397	Sylvania Elect. Prod. Inc., Mt. View Operations	Mountain View, Calif.	15291	Adjustable Bashing Co.	N. Hollywood, Calif.
02660	Amphenol-Borg Electronics Corp.	Broadview, Ill.	07700	Technical Wire Products Inc.	Cranford, N. J.	15566	Amprobe Inst. Corp.	Garden City, Long Island, N. Y.
02735	Radin Corp. of America. Semiconductor and Materials Div.	Somerville, N. J.	07829	Bodine Elect. Co.	Chicago, Ill.	15631	Cabletronics	Lythbrook, N. Y.
02771	Vocaline Co. of America, Inc.	Old Saybrook, Conn.	07829	Continental Device Corp.	Hawthorne, Calif.	15772	Twentieth Century Coil Spring Co.	Costa Mesa, Calif.
02777	Hopkins Engineering Co.	San Fernando, Calif.	07933	Raytheon Mfg. Co., Semiconductor Div.	Mountain View, Calif.	15801	Fenwal Elect. Inc.	Santa Clara, Calif.
02815	Hudson Tool & Die Co.	Newark, N. J.	07980	Howell-Packard Co., Boonton Radio Div.	Boonton, N. J.	15818	Amelco Inc.	Framingham, Mass.
03508	G. E. Semiconductor Prod. Dept.	Syracuse, N. Y.	08145	U. S. Engineering Co.	Rockaway, N. J.	16037	Saruce Pine Mica Co.	Mt. View, Calif.
03705	ApeX Machine & Tool Co.	Dayton, Ohio	08289	Bliha, DelBeri Co.	Los Angeles, Calif.	16179	Omni-Spectra Inc.	Farmington, Mich.
03797	Eidema Corp.	Compton, Calif.	08358	Borgess Bulley Co.	Pasadena, Calif.	16352	Computer Diode Corp.	Lois, N. J.
03818	Parker Seal Co.	Los Angeles, Calif.		Niagara Falls, Ontario, Canada		16385	Boats Aircraft Nut Corp.	Pasadena, Calif.
03877	Transiton Electric Corp.	Wakefield, Mass.	08524	Deutsch Fastener Corp.	Los Angeles, Calif.	16688	Ideal Prec. Water Co., Inc. De Jor Meler Div.	Brooklyn, N. Y.
03888	Pyrofilm Resistor Co., Inc.	Cedar Knolls, N. J.	08564	Bristol Co., The	Waterbury, Conn.	16758	Delco Radio Div. of G. M. Corp.	Kokoma, Ind.
03954	Singer Co., Diehl Div.	Sumerville, N. J.	08717	Sloan Company	San Valley, Calif.	17109	Thermonetics Inc.	Canoga Park, Calif.
04009	Arrow, Hart and Hegeman Elect. Co.	Hartford, Conn.	08718	ITT Cannon Electric Inc., Phoenix Div.	Phoenix, Arizona	17174	Tranex Company	Mountain View, Calif.
04013	Taurus Corp.	Lambertville, N. J.	08727	National Radio Lab. Inc.	Phoenix, Arizona	17554	Component Inc.	Biddeford, Me.
04062	Aico Electronic Inc.	Great Neck, N. Y.	08792	CBS Electronics Semiconductor Operations, Div of G. B. S. Inc.	Paramus, N. J.	17675	Hamlin Metal Products Corp.	Akron, Ohio
04222	Hi-Q Division of Aerovox	Myrtle Beach, S. C.		Lowell, Mass.		17745	Angstrom Prec. Inc.	No. Hollywood, Calif.
04354	Precision Paper Tube Co.	Wheeling, Ill.	08984	Mel-Rain	Cleveland, Ohio	17870	McGraw-Edison Co.	Manchester, N. H.
04404	Dymec Division of Hewlett-Packard Co.	Palo Alto, Calif.	09026	Babcock Rayots Div.	Costa Mesa, Calif.	18042	Powers Design Pacific Inc.	Palo Alto, Calif.
04651	Sylvania Electric Products, Microwave Device Div.	Mountain View, Calif.	09134	Texas Capacitor Co.	Houston, Texas	18083	Clevite Corp., Semiconductor Div.	Palo Alto, Calif.
04673	Dakota Engr. Inc.	Calver City, Calif.	09145	Tech. Ind. Inc. Alohm Elect.	Burbank, Calif.	18324	Signetics Corp.	Sunnyvale, Calif.
04713	Motorola Inc., Semiconductor Prod. Div.	Phoenix, Arizona	09250	Electro Assemblies, Inc.	Chicago, Ill.	18476	Ty-Car Mfg. Co., Inc.	Holliston, Mass.
04732	Filttron Co., Inc. Western Div.	Calver City, Calif.	09353	C & K Components Inc.	Newton, Mass.	18486	TRW Elect. Comp. Div.	Des Plaines, Ill.
04773	Automatic Electric Co.	Northlake, Ill.	09569	Mallory Battery Co. of Canada, Ltd.	Toronto, Ontario, Canada	18583	Curtis Instrument, Inc.	Mt. Kisco, N. Y.
04795	Sequoia Wire Co.	Redwood City, Calif.	09922	Burdyn Corp.	Norwalk, Conn.	18612	Vishay Instruments Inc.	Mt. Vernon, Pa.
04811	Precision Coil Spring Co.	El Monte, Calif.	10124	General Transistor Western Corp.	Los Angeles, Calif.	18873	E. I. DuPont and Co., Inc.	Wilmington, Del.
04870	P. M. Motor Company	Westchester, Ill.	10411	Ti-Tal, Inc.	Berkeley, Calif.	18911	Duraot Mfg. Co.	Milwaukee, Wis.
04919	Component Mfg. Service Co.	W. Birdgewater, Mass.	10646	Carborodum Co.	Niagara Falls, N. Y.	19115	The Beodix Corp., Navigation & Control Div.	Teterboro, N. J.
05006	Twentieth Century Plastics, Inc.	Los Angeles, Calif.	11236	CTS of Berne, Inc.	Berne, Ind.	19100	Thomas A. Edison Industries, Div. of McGraw-Edison Co.	West Orange, N. J.
05245	Compagnots Corp.	Chicago, Ill.	11237	Chicago Telephone of California, Inc.	So. Pasadena, Calif.	19589	Concoa	Baldwin Park, Calif.
05277	Westinghouse Electric Corp. Semi-Conductor Dept.	Youngwood, Pa.	11242	Bay State Electronics Corp.	Waltham, Mass.	19644	LRC Electronics	Horseheads, N. Y.
05347	Ultrox, Inc.	San Mateo, Calif.	11312	Teladyne Inc., Microwave Div.	Palo Alto, Calif.	19701	Electra Mfg. Co.	Independence, Kansas
05397	Union Carbide Corp., Elect. Div.	New York, N. Y.	11314	National Seal	Downey, Calif.	20103	General Ironics Corp.	Philadelphia, Pa.
05574	Viking Ind. Inc.	Canoga Park, Calif.	11453	Precision Connector Corp.	Yonaca, N. Y.	21226	Executoone, Inc.	Long Island City, N. Y.
05593	Icare Electro-Plastics Inc.	Sunnyvale, Calif.				21335	Fabur Bearing Co., The	New Britain, Conn.
						21520	Fansteel Metallurgical Corp.	Chicago, Ill.
						23042	Texscan Corp.	Indianaapolis, Ind.
						23783	British Radio Electronics Ltd.	Washington, D. C.
						24455	G. E. Lamp Division	Nela Park, Cleveland, Ohio

CODE LIST OF MANUFACTURERS (Continued)

Code No.	Manufacturer	Address	Code No.	Manufacturer	Address	Code No.	Manufacturer	Address
24655	General Radio Co.	West Concord, Mass.	71744	Chicago Miniature Lamp Works	Chicago, Ill.	78947	Ucinite Co.	Newtonville, Mass.
24681	Memcor Inc., Comp. Div.	Huntington, Ind.	71785	Cinch Mfg. Co., Howard B. Jones Div.	Chicago, Ill.	79138	Waldes Kohmoor Inc.	Long Island City, N.Y.
24796	Pareico Inc.	San Juan Capistrano, Calif.				79142	Veeder Root, Inc.	Hartford, Conn.
26365	Gries Reproducer Corp.	New Rochelle, N.Y.	71984	Dow Corning Corp.	Midland, Mich.	79253	Webco Mfg. Co.	Chicago, Ill.
28462	Grobel File Co. of America, Inc.		72136	Electro Motive Mfg. Co., Inc.	Williamson, Conn.	79727	Continental-Witt Electronics Corp.	Philadelphia, Pa.
			72619	Dialight Corp.	Brooklyn, N.Y.			
26851	Compac/Hollister Co.	Hollister, Calif.	72656	Indiana General Corp., Electronics Div.	Keasby, N.J.	79963	Zierick Mfg. Corp.	New Rochelle, N.Y.
26992	Hamilton Watch Co.	Lancaster, Pa.				80031	Mepco Division of Sessions Clock Co.	Morristown, N.J.
27251	Specialties Mfg. Co., Inc.	Stallford, Conn.	72699	General Instrument Corp., Cap. Div.	Newark, N.J.			
28480	Hewlett-Packard Co.	Palo Alto, Calif.	72765	Drake Mfg. Co.	Harwood Heights, Ill.	80120	Schnitzer Alloy Products Co.	Elizabeth, N.J.
28520	Heyman Mfg. Co.	Kenilworth, N.J.	72825	Hugh H. Eby Inc.	Philadelphia, Pa.	80131	Electronic Industries Association. Any brand Tube meeting EIA Standards-Washington, DC.	
30817	Instrument Specialties Co., Inc.		72928	Gudeman Co.	Chicago, Ill.	80207	Unimax Switch, Div. Maxon Electronics Corp.	Wallingford, Conn.
			72962	Elastic Slop Nut Corp.	Union, N.J.			
33173	G. E. Receiving Tube Dept.	Dwenshoro, Ky.	72964	Robert M. Hadley Co.	Los Angeles, Calif.	80223	United Transducer Corp.	New York, N.Y.
35434	Leclonm Inc.	Chicago, Ill.	72982	Erie Technological Products, Inc.	Erie, Pa.	80248	Oxford Electric Corp.	Chicago, Ill.
36196	Stanwyck Coil Products Ltd.		73061	Illian Mfg. Co., Inc.	Princeton, Ind.	80294	Acous Inc.	Riverside, Calif.
			73076	H.M. Harper Co.	Chicago, Ill.	80411	Born Div. of Robertshaw Controls Co.	Columbus, Ohio
36287	Cunningham, W.H. & Hill, Ltd.	Hawkesbury, Ontario, Canada	73138	Helipol Div. of Beckman Inst., Inc.	Fullerton, Calif.			
						80486	All Star Products Inc.	Defiance, Ohio
37942	P.R. Mallory & Co. Inc.	Indianapolis, Ind.	73293	Hughes Products Division of Hughes Aircraft Co.	Newport Beach, Calif.	80509	Avery Label Co.	Monrovia, Calif.
39543	Mechanical Industries Prod. Co.	Akron, Ohio				80583	Hammond Co., Inc.	Harris Hill, N.C.
40220	Mixaluron Precision Bearings, Inc.	Keene, N.H.	73445	Amperex Elect. Co.	Hicksville, L.I., N.Y.	80640	Stevens. Arnold. Co., Inc.	Boston, Mass.
42190	Muter Co.	Chicago, Ill.	73506	Bradley Semiconductor Corp.	Rew Haven, Conn.	80813	Dimco Gmb Co.	Dayton, Ohio
43990	C.A. Naigren Co.	Englewood, Colo.	73558	Calling Electric, Inc.	Hartford, Conn.	81030	International Instrumentals Inc.	Orange, Conn.
44655	Ohmite Mfg. Co.	Skokie, Ill.	73586	Circle F Mfg. Co.	Trenton, N.J.	81073	Grayhill Co.	LaGrange, Ill.
46384	Penn Eng. & Mfg. Corp.	Doylstown, Pa.	73682	George K. Garrett Co., Div. MSJ Industries Inc.	Philadelphia, Pa.	81095	Triad Transformer Corp.	Yonkers, Calif.
47500	Polaroid Corp.	Cambridge, Mass.				81312	Winchester Elec. Div. Litton Ind., Inc.	Oakville, Conn.
48200	Precision Thermometer & Inst. Co.		73734	Federal Screw Products Inc.	Chicago, Ill.			
			73743	Fischer Special Mfg. Co.	Cincinnati, Ohio	81349	Military Specification	
49556	Microwave & Power Tube Div.	Southampton, Pa.	73793	General Industries Co., The	Elyria, Ohio	81493	International Rectifier Corp.	El Segundo, Calif.
52090	Rowan Controller Co.	Westminster, Md.	73846	Goshee Stamping & Tool Co.	Goshee, Ind.	81641	Airpax Electronics, Inc.	Cambridge, Maryland
52983	Sanborn Company	Waltham, Mass.	73899	JFB Electronics Corp.	Brooklyn, N.Y.	81960	Barry Controls, Div. Barry Wright Corp.	Watertown, Mass.
54294	Shallicross Mfg. Co.	Seima, N.C.	73905	Jenonics Radio Mfg. Corp.	San Jose, Calif.			
55026	Simpson Electric Co.	Chicago, Ill.	73957	Granv-Pin Corp.	Ridgely, N.J.	82042	Carter Precision Electric Co.	Skokie, Ill.
55933	Sonolone Corp.	Elmsford, N.Y.	74276	Signalite Inc.	Neptune, N.J.	82047	Sperli Faraday Inc., Copper Hewitt Electric Div.	Hoboken, N.J.
55938	Raytheon Co. Commercial Apparatus & Systems Div.	So. Norwalk, Conn.	74455	J.W. Winns, and Soos	Winchester, Mass.			
56137	Spaulding Fibre Co., Inc.	Tonawanda, N.Y.	74861	Industrial Condenser Corp.	Chicago, Ill.	82116	Electric Regulator Corp.	Norwalk, Conn.
56289	Sprague Electric Co.	North Adams, Mass.	74868	R. F. Products Division of Amphenol-Borg Electronics Corp.	Danbury, Conn.	82142	Jeffers Electronics Division of Sperry Corp.	Do Bois, Pa.
59446	Tetea Corp.	Tulsa, Okla.	74970	E. F. Johnson Co.	Waseca, Minn.	82170	Fairchild Camera & Inst. Corp. Space & Defense System Div.	Paramus, N.J.
59730	Thomas & Belts Co.	Elizabeth, N.J.	75042	International Resistance Co.	Philadelphia, Pa.	82209	Maguire Industries, Inc.	Greenwich, Conn.
60741	Triplett Electrical Inst. Co.	Bluffton, Ohio	75263	Keystone Carbon Co., Inc.	St. Marys, Pa.	82219	Sylvania Electric Prod. Inc. Electronic Tube Division	Emporium, Pa.
61775	Union Switch and Signal, Div. of Westinghouse Air Brake Co.	Pittsburgh, Pa.	75378	CTS Knights Inc.	Sandwich, Ill.	82376	Astron Corp.	East Newark, Harrison, N.J.
			75382	Kulka Electric Corporation	Chicago, Ill.	82389	Schwartzl, Inc.	Chicago, Ill.
62119	Universal Electric Co.	Owosso, Mich.	75818	Lenz Electric Mfg. Co.	Chicago, N.Y.	82647	Metals & Controls Inc. Spencer Products	Allioboro, Mass.
63743	Ward-Leonard Electric Co.	Mt. Vernon, N.Y.	75915	Littlefuse, Inc.	Des Plaines, Ill.			
64959	Western Electric Co., Inc.	New York, N.Y.	76005	Loté Mfg. Co.	Elio, Pa.	82768	Phillips-Advanca Control Co.	Joliet, Ill.
65092	Weslon Inst. Inc. Weslon-Newark	Newark, N.J.	76210	C.W. Mawwedel	San Francisco, Calif.	82866	Research Products Corp.	Madison, Wis.
66295	Wittek Mfg. Co.	Chicago, Ill.	76433	General Instrument Corp., Micromold Division	Newark, N.J.	82677	Rotron Mfg. Co., Inc.	Woodstock, N.Y.
66346	Minnesota Mining & Mfg. Co. Reverse Wincom Div.	St. Paul, Minn.				82893	Vector Electronic Co.	Glendale, Calif.
			76487	James Millen Mfg. Co., Inc.	Malden, Mass.	83014	Hartwell Corp.	Los Angeles, Calif.
70276	Altee Mfg. Co.	Hartford, Conn.	76493	J.W. Miller Co.	Los Angeles, Calif.	83058	Carr Fastener Co.	Cambridge, Mass.
70309	Allied Control	New York, N.Y.	76530	Cinch-Monadnock, Div. of United Carr Fastener Corp.	San Leandro, Calif.	83086	New Hampshire Ball Bearing, Inc.	Peterborough, N.H.
70318	Aluminum Screw Product Co., Inc.							
			76545	Mueller Electric Co.	Cleveland, Ohio	83125	General Instrument Corp., Capacitor Div.	Darlington, S.C.
70417	Amplex, Div. of Chrysler Corp.	Detroit, Mich.	76703	National Union	Newark, N.J.	83348	ITT Wire and Cable Div.	Los Angeles, Calif.
70485	Atlantic India Rubber Works, Inc.	Chicago, Ill.	76854	Oak Manufacturing Co.	Crystal Lake, Ill.	83186	Victory Eng. Corp.	Springfield, N.J.
70563	Ampelite Co., Inc.	Union City, N.J.	77068	The Bendix Corp., Electrodynamics Div.	N. Hollywood, Calif.	83298	Bendix Corp., Red Bank Div.	Red Bank, N.J.
70674	ADC Products Inc.	Minneapolis, Minn.				83315	Muhbell Corp.	Mundelein, Ill.
70903	Belden Mfg. Co.	Chicago, Ill.	77075	Pacific Metals Co.	San Francisco, Calif.	83324	Rosan Inc.	Newport Beach, Calif.
70998	Bird Electronic Corp.	Cleveland, Ohio	77221	Phanotron Instrument and Electronic Co.	South Pasadena, Calif.	83330	Smith, Herman H., Inc.	Brooklyn, N.Y.
71002	Birnback Radio Co.	New York, N.Y.				83332	Tech Labs	Parsippany Park, N.J.
71034	Bitley Electric Co., Inc.	Erie, Pa.	77252	Philadelphia Steel and Wire Corp.	Philadelphia, Pa.	83385	Central Screw Co.	Chicago, Ill.
71041	Bosloo Gear Works Div. of Murray Co. of Texas	Quincy, Mass.				83501	Gavitt Wire and Cable Co. Div. of Amerace Corp.	Brookfield, Mass.
71218	Bud Radio, Inc.	Willoughby, Ohio	77342	American Machine & Foundry Co. Potter & Brunfeldt Div.	Princeton, Ind.	83594	Borroughs Corp. Electronic Tube Div.	Plainfield, N.J.
71279	Cambridge Thermionics Corp.	Cambridge, Mass.	77630	TRW Electronic Components Div.	Camden, N.J.			
71286	Camloc Fastener Corp.	Paramus, N.J.	77638	General Instrument Corp., Rectifier Div.	Brooklyn, N.Y.	83740	Union Carbide Corp. Consumer Prod. Div.	New York, N.Y.
71313	Cardwell Condenser Corp.							
			77764	Resistance Products Co.	Harrisburg, Pa.	83777	Model Eng. and Mfg., Inc.	Nonlogins, Ind.
71400	Bossmann Mfg. Div. of McGraw-Edison Co.	Lindenhurst, L.I., N.Y.	77969	Rubbercraft Corp. of Calif.	Torrance, Calif.	83821	Loyd Scruggs Co.	Festus, Mo.
			78189	Shakeproof Division of Illinois Tool Works	Elgin, Ill.	83942	Aeronautical Inst. & Radio Co.	Lodi, N.J.
71436	Chicago Condenser Corp.	Chicago, Ill.				84171	Arco Electronics Inc.	Great Neck, N.Y.
71447	Calif. Spring Co., Inc.	Pico-Rivera, Calif.	78277	Sigma	Sa. Braintree, Mass.	84396	A.J. Giesener Co., Inc.	San Francisco, Calif.
71450	CTS Corp.	Elkhall, Ind.	78283	Signal Indicator Corp.	New York, N.Y.	84411	TRW Capacitor Div.	Dogalska, Neb.
71468	ITT Cannon Electric Inc.	Los Angeles, Calif.	78290	Situthars-Dunn Inc.	Pitman, N.J.	84970	Sarkes Tarzjan, Inc.	Bloomington, Ind.
71471	Cinema, Div. Aerovox Corp.	Burbank, Calif.	78424	Speciality Leather Prod. Co.	Newark, N.J.	85454	Bonnton Molding Company	Bonnton, N.J.
71482	C.P. Clare & Co.	Chicago, Ill.	78452	Thompson-Bremer & Co.	Chicago, Ill.	85471	A.B. Boyd Co.	San Francisco, Calif.
71590	Centralab Div. of Globe Union Inc.		78471	Tilley Mfg. Co.	San Francisco, Calif.	85474	R.M. Bracamonte & Co.	San Francisco, Calif.
			78498	Stackpole Carbon Co.	St. Marys, Pa.			
71616	Commercial Plastics Co.	Milwaukee, Wis.	78493	Standard Thomson Corp.	Waltham, Mass.			
71700	Cornish Wire Co., The	Chicago, Ill.	78553	Tinnerman Products, Inc.	Cleveland, Ohio			
71707	Cofco Coil Co., Inc.	Providence, R.I.	78790	Transformer Engineers	San Gabriel, Calif.			

HEWLETT • PACKARD SALES AND SERVICE

UNITED STATES

ALABAMA

P.O. Box 4207
2003 Byrd Spring Road S.W.
Huntsville 35802
Tel: (205) 881-4591
TWX: 810-726-2204

ARIZONA

3009 North Scottsdale Road
Scottsdale 85251
Tel: (602) 945-7601
TWX: 910-950-1282

5737 East Broadway
Tucson 85716
Tel: (602) 298-2313
TWX: 910-952-1162

CALIFORNIA

1430 East Orangethorpe Ave.
Fullerton 92631
Tel: (714) 870-1900

3939 Lankershim Boulevard
North Hollywood 91604
Tel: (213) 877-1282
TWX: 810-499-2170

1101 Embarcadero Road
Palo Alto 94303
Tel: (415) 327-6500
TWX: 910-373-1280

2591 Carlsbad Avenue
Sacramento 95821
Tel: (916) 482-1463
TWX: 910-367-2092

1055 Shafter Street
San Diego 92106
Tel: (714) 223-8103
TWX: 910-335-2000

COLORADO

7965 East Prentice
Englewood 80110
Tel: (303) 771-3455
TWX: 910-935-0705

CONNECTICUT

508 Tolland Street
East Hartford 06108
Tel: (203) 289-9394
TWX: 710-425-3416

111 East Avenue
Norwalk 06851
Tel: (803) 853-1251
TWX: 710-468-3750

DELAWARE

3941 Keanett Pike
Wilmington 19807
Tel: (302) 655-6161
TWX: 510-666-2214

FLORIDA

P.O. Box 545
Suite 106
9999 N.E. 2nd Avenue
Miami Shores 33153
Tel: (305) 754-4555
TWX: 810-848-7252

P.O. Box 20007
Herndon Station 32814
621 Commonwealth Avenue
Orlando
Tel: (305) 841-3970
TWX: 810-850-0113

P.O. Box 8128
Madelra Beach 33708
410 150th Avenue
St. Petersburg
Tel: (613) 391-0211
TWX: 810-863-0366

GEORGIA

P.O. Box 28234
450 Interstate North
Atlanta 30328
Tel: (404) 436-6181
TWX: 810-766-8890

ILLINOIS

5500 Howard Street
Skokie 60076
Tel: (312) 677-0400
TWX: 910-223-3613

INDIANA

4002 Meadows Drive
Indianapolis 46205
Tel: (317) 546-4891
TWX: 810-341-3 63

LOUISIANA

P.O. Box 856
1942 Williams Boulevard
Kenner 70062
Tel: (504) 721-8201
TWX: 810-955-5524

MARYLAND

6707 Whitestone Road
Baltimore 21207
Tel: (301) 944-5400
TWX: 710-862-0850

MASSACHUSETTS

P.O. Box 1648
2 Choke Cherry Road
Reverie 02850
Tel: (301) 948-6370
TWX: 710-828-9684

MICHIGAN

24315 Northwestern Highway
Southfield 48075
Tel: (313) 353-9100
TWX: 0-232-1532

MINNESOTA

2459 University Avenue
St. Paul 55114
Tel: (612) 845-9461
TWX: 910-563-3734

MISSOURI

9208 Wyoming Place
Kansas City 64114
Tel: (816) 333-2445
TWX: 910-771-2087

2812 South Brentwood Blvd.
St. Louis 63144
Tel: (314) 962-5000
TWX: 910-760-1670

NEW JERSEY

W. 120 Century Road
Paramus 07652
Tel: (201) 285-5000
TWX: 710-990-4951

1060 N. Kings Highway
Cherry Hill 08034
Tel: (609) 667-4000
TWX: 710-892-4945

NEW MEXICO

P.O. Box 8366
Station C
6501 Lomas Boulevard N.E.
Albuquerque 87104
Tel: (505) 255-5586
TWX: 910-989-1665

156 Wyatt Drive
Las Cruces 88001
Tel: (505) 526-2485
TWX: 910-963-0550

NEW YORK

1702 Central Avenue
Albany 12205
Tel: (518) 868-8482
TWX: 710-441-8270

1219 Campville Road
Endicott 13764
Tel: (607) 754-0050
TWX: 510-252-0890

82 Washington Street
Poughkeepsie 12601
Tel: (914) 454-7330
TWX: 510-248-0012

39 Saginaw Drive
Rochester 14623
Tel: (718) 473-9500
TWX: 510-253-5981

1025 Northern Boulevard
Roslyn, Long Island 11576
Tel: (516) 869-8400
TWX: 510-223-0811

5858 East Molloy Road
Syracuse 13211
Tel: (315) 454-2486
TWX: 710-541-0482

NORTH CAROLINA

P.O. Box 5188
1923 North Main Street
High Point 27282
Tel: (919) 882-6873
TWX: 510-926-1516

OHIO

25575 Center Ridge Road
Cleveland 44145
Tel: (216) 835-0300
TWX: 810-427-9129

3460 South Dixie Drive
Dayton 45439
Tel: (513) 298-0351
TWX: 810-458-1925

OKLAHOMA

2919 United Founders Boulevard
Oklahoma City 73112
Tel: (405) 848-2801
TWX: 910-830-8862

OREGON

Westhills Mall, Suite 158
4475 S.W. Scholls Ferry Road
Portland 97225
Tel: (503) 292-9171
TWX: 910-464-6103

PENNSYLVANIA

2500 Moss Side Boulevard
Monroeville 15146
Tel: (412) 271-0724
TWX: 710-797-3650

1021 8th Avenue
King of Prussia Industrial Park
King of Prussia 19406
Tel: (215) 265-7000
TWX: 510-660-2670

RHODE ISLAND

873 Waterman Ave.
East Providence 02914
Tel: (401) 434-5535

TEXAS

P.O. Box 1270
201 E. Arapahoe Rd.
Richardson 75080
Tel: (214) 231-8101
TWX: 910-867-4 23

P.O. Box 22813
4242 Richetond Avenue
Houston 77027
Tel: (713) 867-2407
TWX: 810-881-2645

GOVERNMENT CONTRACT OFFICE

225 Billy Mitchell Road
San Antonio 78226
Tel: (512) 434-4171
TWX: 910-871-1170

UTAH

2890 South Main Street
Salt Lake City 84115
Tel: (801) 486-8156
TWX: 910-925-5681

VIRGINIA

P.O. Box 6514
2111 Spencer Road
Richmond 23230
Tel: (703) 282-5451
TWX: 710-956-0157

WASHINGTON

433-106th N.E.
Bellevue 98004
Tel: (206) 454-3971
TWX: 910-443-2303

FOR U.S. AREAS NOT LISTED:

Contact the regional office nearest you: Atlanta, Georgia... North Hollywood, California... Paramus, New Jersey... Skokie, Illinois. Their complete addresses are listed above.

CANADA

ALBERTA

Hewlett-Packard (Canada) Ltd.
11745 Jasper Ave.
Edmonton
Tel: (403) 482-5561
TWX: 610-831-2431

BRITISH COLUMBIA

Hewlett-Packard (Canada) Ltd.
304-1637 West Broadway
Vancouver 9
Tel: (604) 738-5301
TWX: 610-922-5059

MANITOBA

Hewlett-Packard (Canada) Ltd.
511 Bradford Ct.
St. James
Tel: (204) 786-7581

NOVA SCOTIA

Hewlett-Packard (Canada) Ltd.
2745 Dutch Village Rd.
Suite 203
Halifax
Tel: (902) 455-0511
TWX: 610-271-4482

ONTARIO

Hewlett-Packard (Canada) Ltd.
880 Lady Egan Place
Ottawa # 3
Tel: (613) 722-4223
TWX: 610-582-1952

Hewlett-Packard (Canada) Ltd.

1415 Lawrence Avenue West
Toronto
Tel: (416) 249-9196
TWX: 610-492-2382

QUEBEC

Hewlett-Packard (Canada) Ltd.
275 Hymus Boulevard
Pointe Claire
Tel: (514) 697-4232
TWX: 610-422-3022
Telex: 01-20607

FOR CANADIAN AREAS NOT LISTED:

Contact: Hewlett-Packard (Canada) Ltd. in Pointe Claire, at the complete address listed above.

CENTRAL AND SOUTH AMERICA

ARGENTINA

Hewlett-Packard Argentina
S.A.C. Ltda.
Lavalle 1171-3°
Buenos Aires
Tel: 35-0436, 35-0627, 35-0431
Telex: 012-1009
Cable: HEWPACKARC

BRAZIL

Hewlett-Packard Do Brasil
l.e.C. Ltda.
Rua Coronel Oscar Porto, 691
São Paulo - 8. SP
Tel: 71-1503
Cable: HEWPACK São Paulo

Hewlett-Packard Do Brasil

l.e.C. Ltda.
Avenida Franklin Roosevelt 84-
grupo 203
Rio de Janeiro, 2C-39. GB
Tel: 32-9733
Cable: HEWPACK Rio de Janeiro

CHILE

Hector Calcagni P.
Castilla 13942
Estado 215 - Oficina 1016
Santiago
Tel: 31-890, 490-505

COLOMBIA

Instrumentación
Henrik A. Langebaek & Kier
Ltda.
Carrera 7 # 48-59
Apartado Aéreo 6287
Bogotá, I.D.E.
Tel: 45-78-06, 45-55-46
Cable: AARIS Bogotá

COSTA RICA

Lic. Alfredo Gallegos Gurdilán
Apartado 3243
San José
Tel: 21-85-13
Cable: GALGUR San José

ECUADOR

Laboratorios de Radio-Ingeniería
Calle Guayaquil 1246
Post Office Box 3199
Quito
Tel: 12496
Cable: HORYATH Quito

EL SALVADOR

Electrónica
Roberto Terán G.
Apartado Postal 1509
27 Avenida Norte 1133
San Salvador
Tel: 25-74-50
Cable: ELECTRONICA
San Salvador

GUATEMALA

D'andor Associates Latin America
Laborado 1226
7a. Calle, 0-22, Zona 1
Guatemala City
Tel: 22812
Cable: OLALA Guatemala City

MEXICO

Hewlett-Packard Mexicana, S.A.
de C.V.
Moras 439
Col. del Valle
Mexico 12, D.F.
Tel: 75-46-49

NICARAGUA

Roberto Terán G.
Apartado Postal 689
Edificio Terán
Managua
Tel: 3451, 3452
Cable: ROTERAN Managua

PANAMA

Electrónica Balboa, S.A.
P.O. Box 4929
Ave. Manuel Espinosa No. 13-50
Bldg. Alina
Panama City
Tel: 30833
Cable: ELECTRON Panama City

PERU

Fernando Ezeta B.
Avenida Petit Thouars 4719
Miraflores
Casilla 3061
Lima
Tel: 50346
Cable: PEPERU Lima

PUERTO RICO

San Juan Electronics, Inc.
P.O. Box 5167
Ponce de Leon 154
Pda. 3-Plta. de Tierra
Tel: (809) 725-3342
Cable: SATRONICS San Juan
Telex: SATRON 3450 332

URUGUAY

Pablo Ferrando S.A.
Comercial e Industrial
Avenida Italia 2877
Casilla de Correo 370
Montevideo
Tel: 40-3102

VENEZUELA

Hewlett-Packard de Venezuela
C.A.
Apartado del Este 10934
Chacao
Caracas
Tel: 71.88.05, 71.88.69, 71.88.76
Cable: HEWPACK Caracas

FOR AREAS NOT LISTED,

CONTACT:
Hewlett-Packard Inter-Americas
3200 Hillview Ave.
Palo Alto, California 94304
Tel: (415) 326-7000
TWX: 910-373-1267
Cable: HEWPACK Palo Alto
Telex: 034-8461

HEWLETT • PACKARD SALES AND SERVICE

EUROPE

AUSTRIA

Unilabor GmbH
Wissenschaftliche Instrumente
Rummelhardtsgasse 6/3
P.O. Box 33
Vienna A-1095
Tel: 4 26 181
Cable: IABORINSTRUMENT
Vienna
Telex: 75 762

BELGIUM

Hewlett-Packard Benelux S.A.
348 Boulevard du Souverain
Brussels 16
Tel: 72 22 40
Cable: PALOBEN Brussels
Telex: 23 494

DENMARK

Hewlett-Packard A/S
Langebjerg 6
2850 Naerum
Tel: (01) 80 40 40
Cable: HEWPACK A/S
Telex: 66 40

FINLAND

Hewlett-Packard Oy
Gyldenintie 3
Helsinki 20
Tel: 67 35 38
Cable: HEWPACKOY-Helsinki
Telex: 12-1563

FRANCE

Hewlett-Packard France
Quartier de Courtabouef
Boite Postale No. 6
91 Orsay
Tel: 920 88 01
Cable: HEWPACK Orsay
Telex: 60048 HEWPACK ORSAY

Hewlett-Packard France
4 Quai des Etoiles
69 Lyon 5e
Tel: 42 63 45
Cable: HEWPACK Lyon
Telex: 31617

GERMANY

Hewlett-Packard Vertriebs-GmbH
Lietzenburgerstrasse 30
1 Berlin W 30
Tel: 2460 65/66
Telex: 18 34 05

Hewlett-Packard Vertriebs-GmbH
Herrenbergerstrasse 110
703 Böblingen, Württemberg
Tel: 07031-6671
Cable: HEPAG Böblingen

Telex: 72 65 739
Hewlett-Packard Vertriebs-GmbH
Achenbachstrasse 15
4 Düsseldorf 1
Tel: 68 52 58/59
Telex: 85 86 533

Hewlett-Packard Vertriebs-GmbH
Kurfürstenstrasse 95
6 Frankfurt 50
Tel: 52 00 36
Cable: HEWPACKSA Frankfurt
Telex: 41 32 49

Hewlett-Packard Vertriebs-GmbH
Beim Strohhause 26
2 Hamburg 1
Tel: 24 05 51/52
Cable: HEWPACKSA Hamburg
Telex: 21 53 32

Hewlett-Packard Vertriebs-GmbH
Reginfriedstrasse 13
8 München 9
Tel: 0811 69 59 71/75
Cable: HEWPACKSA München
Telex: 524985

GREECE

Kostas Karayannis
18, Ermou Street
Athens 126
Tel: 230 301
Cable: RAKAR Athens
Telex: 21 59 62

IRELAND

Hewlett-Packard Ltd.
224 Bath Road
Slough, Bucks, England
Tel: Slough 753-3334
Cable: HEWP/E Slough
Telex: 84413

ITALY

Hewlett-Packard Italiana S.P.A.
Viale Lunigiana 46
20125 Milan
Tel: 69 15 84
Cable: HEWPACKIT Milan
Telex: 32046

Hewlett-Packard Italiana S.P.A.
Palazzo Italia
Piazza Marconi 25
00144 Rome-Eur
Tel: 591 2544
Cable: HEWPACKIT Rome
Telex: 61514

NETHERLANDS

Hewlett-Packard Benelux, N.V.
Weederstein 117
Amsterdam, Z II
Tel: 42 7 777
Cable: PALOBEN Amsterdam
Telex: 13 216

NORWAY

Hewlett-Packard Norge A/S
Box 149
Nesveien 13
Oslo
Tel: 53 83 60
Cable: HEWPACK Oslo
Telex: 6621

PORTUGAL

Telectra
Rua Rodrigo da Fonseca 103
P.O. Box 2531
Lisbon 1
Tel: 68 60 72
Cable: TELETRACTA Lisbon
Telex: 1598

SPAIN

Atalo Ingenieros
Ganduxer 76
Barcelona 6
Tel: 211 44-66

Atajo Ingenieros
Enrique Larrate 12
Madrid, 18
Tel: 235 43 44
Cable: TELEATIO Madrid
Telex: 2 72 49

SWEDEN

Hewlett-Packard (Sverige) AB
Nagakersgatan 9C
431 04 Mölndal 4
Tel: 031-27 68 00

Hewlett-Packard (Sverige) AB
Svetsvägen 7
S171 20 Solna 1
Tel: (08) 98 12 50
Cable: MEASUREMENTS
Stockholm
Telex: 10721

SWITZERLAND

Hewlett-Packard (Schweiz) AG
Zürcherstrasse 20
8952 Schlieren
Zürich
Tel: (051) 98 18 21/24
Cable: HEWPACKAG Zurich
Telex: 53933

Hewlett-Packard (Schweiz) A.G.
Rue du Bols-du-Lan 7
1217 Meyrin-Geneva
Tel: (022) 41 54 00
Cable: HEWPACKSA Geneva
Telex: 2 24 86

TURKEY

Telekom Engineering Bureau
P.O. Box 376- Galata
Istanbul
Tel: 48 40 40
Cable: TELEMATION Istanbul

UNITED KINGDOM

Hewlett-Packard Ltd.
224 Bath Road
Slough, Bucks
Tel: Slough 753-3334
Cable: BELRAMEL Slough
Telex: 84413

YUGOSLAVIA

Bnlram S.A.
83 avenue des Mimosas
Brussels 15, Belgium
Tel: 34 33 32, 34 26 19
Cable: BELRAMEL Brussels
Telex: 21790

FOR AREAS NOT LISTED, CONTACT:

Hewlett-Packard S.A.
Rue du Bois-du-Lan 7
1217 Meyrin-Geneva
Tel: (022) 41 54 00
Cable: HEWPACKSA Geneva
Telex: 2.24.86

AFRICA, ASIA, AUSTRALIA

ANGOLA

Telectra Empresa Técnica
de Equipamentos Eléctricos
SAR
Rua de Barbosa Rodrigues
42-1º
Box 6487
Luanda
Cable: TELECTRA Luanda

AUSTRALIA

Hewlett-Packard Australia
Pty. Ltd.
22-26 Weir Street
Glen Iris, 3146
Victoria
Tel: 20.1371 (4 lines)
Cable: HEWPARD Melbourne
Telex: 31024

Hewlett-Packard Australia
Pty. Ltd.
61 Alexander Street
Grewa Nest 2065
New South Wales
Tel: 43-7866
Cable: HEWPARD Sydney

Hewlett-Packard Australia
Pty. Ltd.
97 Churchill Road
Prospect 5082
South Australia
Tel: 65-2366
Cable: HEWPARD Adelaide

Hewlett-Packard Australia
Pty. Ltd.
2nd Floor, Suite 13
Casablanca Buildings
196 Adelaide Terrace
Perth, W.A. 6000

CEYLON

United Electricals Ltd.
P.O. Box 681
Yehala Building
Staples Street
Colombo 2
Tel: 5496
Cable: HOTPOINT Colombo

CYPRUS

Kytronics
19-19D Hommer Avenue
P.O. Box 752
Nicosia
Tel: 6282-75628
Cable: HE-I-NAMI

ETHIOPIA

African Salespower & Agency
Private Ltd., Co.
P.O. Box 718
58/59 Cunningham St.
Addis Ababa
Tel: 12285
Cable: ASACO Addisababa

HONG KONG

Schmidt & Co. (Hong Kong) Ltd.
P.O. Box 297
1511, Prince's Building
10, Chater Road
Hong Kong
Tel: 24016B, 232736
Cable: SCHMIDTCO Hong Kong

INDIA

The Scientific Instrument
Co., Ltd.
6, Tej Bahadur Sapru Road
Allahabad 1
Tel: 2451
Cable: SICO Allahabad

The Scientific Instrument
Co., Ltd.
240, Dr. Dadabhai Naoroji Road
Bombay 1
Tel: 26-2642
Cable: SICO Bombay

The Scientific Instrument
Co., Ltd.
11, Esplanade East
Calcutta 1
Tel: 23-4129
Cable: SICO Calcutta

The Scientific Instrument Co., Ltd.
30, Mount Road
Madras 2
Tel: 86339
Cable: SICO Madras

The Scientific Instrument Co. Ltd.
5-8-525 Mahatma Gandhi Road
Hyderabad-1 (A-P) India
Cable: SICO Hyderabad

The Scientific Instrument Co., Ltd.
8-7, Ajmeri Gate Extn.
New Delhi 1
Tel: 27-1053
Cable: SICO New Delhi

INDONESIA

Bah Boien Trading Coy. N.V.
Djalih Merdeka 29
Bandung

IRAN

Telecom, Ltd.
P.O. Box 1812
240 Kh. Saba Shomali
Tehran
Tel: 43850, 48113
Cable: BASCOM Teheran

ISRAEL

Electronics & Engineering
Div. of Motorola Israel Ltd.
18, Xremenetski Street
Tel-Aviv
Tel: 35021 (8 lines)
Cable: BA STEL Tel-Aviv
Telex: Basteiv 033-969

JAPAN

Yokogawa-Hewlett-Packard Ltd.
Nisei Ibaragi Bldg.
2-2-8 Kasuga
Ibaragi-Shi
Osaka
Tel: 23-1641

Yokogawa-Hewlett-Packard Ltd.
Ito Building
No. 59, Kotori-cho
Makamura-ku, Nagoya City
Tel: 551-0215

Yokogawa-Hewlett-Packard Ltd.
Obasiri Building
5-9 Yoyogi 1-chrome
Shibuya-ku, Tokyo
Tel: 370-2281
Telex: 232-2024YHP
Cable: YHPMARKET TOK 23-724

KENYA

R. J. Tilbury Ltd.
P.O. Box 2754
Suite 517/518
Hotel Ambassadeur
Nairobi
Tel: 25670, 26803, 68206, 58196
Cable: ARJAYTEE Nairobi

KOREA

American Trading Co., Korea, Ltd.
P.O. Box 1103
Dae Kyung Bldg.
107 Sejong Ro
Chongro Ku
Seoul
Tel: 75-5841 (4 lines)
Cable: AMTRACO Seoul

LEBANON

Constantin E. Macridis
Clemenceau Street
Clemenceau Center
Beirut
Tel: 220846
Cable: ELECTRONUCLEAR Beirut

MALAYSIA

MECOMB Malaysia Ltd.
2 Lorong 13/6A
Section 13
Petaling Jaya, Seteangar
Cable: MECOMB Kuala Lumpur

MOZAMBIQUE

A. N. Goncalves, LDA.
4.1 Apt. 14 Av. D. Luis
P.O. Box 107
Lourenco Marques
Cable: NECON

NEW ZEALAND

Hewlett-Packard (N.Z.) Ltd.
32-34 Kent Terrace
P.O. Box 9443
Wellington, N.Z.
Tel: 56-409
Cable: HEWPACK Wellington

PAKISTAN (EAST)

Mushko & Company, Ltd.
31, Jinnah Avenue
Dacca
Tel: 80058
Cable: HEWDEAL Dacca

PAKISTAN (WEST)

Mushko & Company, Ltd.
Osman Chambers
Victoria Road
Karachi 3
Tel: 51027, 52927
Cable: COOPERATOR Karachi

PHILIPPINES

Electromex Inc.
2129 Pasong Tamo
Makati, Rizal
P.O. Box 4326
Manila
Tel: 88-91-71 or 88-83-76
Cable: ELEMEX Manila

SINGAPORE

Mechanical and Combustion
Engineering Company Ltd.
9, Jalan Kilang
Singapore, 3
Tel: 642361-3
Cable: MECOMB Singapore

SOUTH AFRICA

Hewlett-Packard South Africa
(Pty.), Ltd.
111 House
43 Somerset Rd.
Cape Town
Tel: 3-6019
Cable: HEWPACK Cape Town
Telex: 7038CT

Hewlett-Packard South Africa
(Pty.), Ltd.
P.O. Box 31716
39 De Beer Street
Braamfontein, Johannesburg
Tel: 724-4172 724-4195
Telex: 0226 IH

Cable: HEWPACK Johannesburg

Hwa Sheng Electronic Co., Ltd.
P.O. Box 1558
Room 604
Chia Hsin Building
No. 96 Chung Shan
North Road, Sec. 2
Taipei
Tel: 555211 Ext. 532-539
Cable: VICTRONIX Taipei

Hwa Sheng Electronic Co., Ltd.
P.O. Box 1558
Room 604
Chia Hsin Building
No. 96 Chung Shan
North Road, Sec. 2
Taipei
Tel: 555211 Ext. 532-539
Cable: VICTRONIX Taipei

Hwa Sheng Electronic Co., Ltd.
P.O. Box 1558
Room 604
Chia Hsin Building
No. 96 Chung Shan
North Road, Sec. 2
Taipei
Tel: 555211 Ext. 532-539
Cable: VICTRONIX Taipei

Hwa Sheng Electronic Co., Ltd.
P.O. Box 1558
Room 604
Chia Hsin Building
No. 96 Chung Shan
North Road, Sec. 2
Taipei
Tel: 555211 Ext. 532-539
Cable: VICTRONIX Taipei

Hwa Sheng Electronic Co., Ltd.
P.O. Box 1558
Room 604
Chia Hsin Building
No. 96 Chung Shan
North Road, Sec. 2
Taipei
Tel: 555211 Ext. 532-539
Cable: VICTRONIX Taipei

Hwa Sheng Electronic Co., Ltd.
P.O. Box 1558
Room 604
Chia Hsin Building
No. 96 Chung Shan
North Road, Sec. 2
Taipei
Tel: 555211 Ext. 532-539
Cable: VICTRONIX Taipei



MANUAL BACKDATING CHANGES

Model 400GL

AC VOLTMETER

This manual backdating sheet makes this manual applicable to earlier instruments. Instrument-component values that differ from those in the manual, yet are not listed in the backdating sheet, should be replaced using the part number given in the manual.

Instrument Serial Prefix	Make Manual Changes	Instrument Serial Prefix	Make Manual Changes
Below 628-00151	CHANGE #1		
Below 737-00456	CHANGE #2		

CHANGE #1: Part No. of A1K1 is 0490-0195.

CHANGE #2: Preampifier is as shown on Page 6-4.

Part No. of A1 is 00400-66505.

Part No. of A1K1 is 0490-0478 except as listed in CHANGE #1.

